

STATE OF TEXAS  
COUNTY OF MONTGOMERY

FILED FOR RECORD  
99 MAR 19 PM 2:26

MARK TURNBULL, CLERK  
MONTGOMERY COUNTY, TEXAS  
DEPUTY

THE WOODLANDS LAND DEVELOPMENT COMPANY, L.P., acting herein by and through the WOODLANDS OPERATING COMPANY, L.P. its authorized agent, acting herein by and through its President and Chief Executive Officer, Michael H. Richmond, owner (hereinafter referred to as "owner") of the property subdivided in the above and foregoing map of THE WOODLANDS VILLAGE OF ALDEN BRIDGE, SECTION 67, do hereby make subdivision of said property for and on behalf of said THE WOODLANDS LAND DEVELOPMENT COMPANY, L.P., according to the lines, streets, lots, alleys, parks, building lines, and easements thereon shown and designate said subdivision as THE WOODLANDS VILLAGE OF ALDEN BRIDGE, SECTION 67. Located in the Dickinson Garrett Survey, Abstract 224, in Montgomery County, Texas and on behalf of said THE WOODLANDS LAND DEVELOPMENT COMPANY, L.P.; and dedicate to public use, as such, the streets, alleys, parks and easements shown thereon forever; and do hereby waive any claims for damages occasioned by the establishing of grades as approved for the streets and alleys dedicated, or occasioned by the alteration of the surface of any portion of streets or alleys to conform to such grades; and do hereby bind myself, our successors and assigns to warrant and forever defend the title to the land so dedicated.

THIS is to certify that THE WOODLANDS LAND DEVELOPMENT COMPANY, L.P., acting herein by and through THE WOODLANDS OPERATING COMPANY, L.P. its authorized agent, acting herein by and through its President and Chief Executive Officer, Michael H. Richmond, Owner of the property subdivided in the above foregoing map of THE WOODLANDS VILLAGE OF ALDEN BRIDGE, SECTION 67, have complied or will comply with all regulations heretofore on file with the Montgomery County Engineer and adopted by the Commissioner's Court of Montgomery County, Texas.

FURTHER, Owner has dedicated and by these presents does dedicate to the use of the public for public utility purposes forever unobstructed aerial easements. The aerial easements shall extend horizontally an additional eleven feet, six inches (11'-6") for ten feet (10'-0") perimeter ground easements or five feet six inches (5'-6") for sixteen feet (16'-0") perimeter ground easements, from a plane sixteen feet (16'-0") above ground level upward, located adjacent to and adjoining said public utility easements that are designated with aerial easements (U.E. & A.E.) as indicated and depicted hereon, whereby the aerial easement totals twenty one feet, six inches (21'-6") in width.

FURTHER, Owner has dedicated and by these presents does dedicate to the use of the public for public utility purposes forever unobstructed aerial easements. The aerial easements shall extend horizontally an additional ten feet (10'-0") for ten feet (10'-0") back-to-back ground easements or seven feet (7'-0") for sixteen feet (16'-0") back-to-back ground easements, from a plane sixteen feet (16'-0") above ground level upward, located adjacent to both sides and adjoining said public utility easements that are designated with aerial easements (U.E. & A.E.) as indicated and depicted hereon, whereby the aerial easement totals thirty feet (30'-0") in width.

FURTHER, Owner does hereby dedicate forever to the public a strip, a minimum of land fifteen feet (15'-0") wide on each side of the centerline of any and all gullies, ravines, draws sloughs, or other natural drainage courses located in the said subdivision, as easements for drainage purposes, giving Montgomery County and/or any other public agency the right to enter upon said easements at any and all times for the purpose of constructing and/or maintaining drainage work and/or structures.

FURTHER, all of the property subdivided in the above and foregoing map shall be restricted in its use, which restrictions shall run with the title to the property, and shall be enforceable at the option of Montgomery County, by Montgomery County or any citizen thereof, by injunction as follows:

- 1) That drainage of septic tanks into any road, street, alley or other public ditches, either directly or indirectly, is strictly prohibited.
- 2) Drainage structures under private driveways shall have a net drainage opening area of sufficient size to permit the free flow of water without backwater, and shall be a minimum of one and three quarters (1-3/4) square feet (18" diameter pipe culvert).

FURTHER, Owner does hereby declare that all parcels of land designated as lots on this plat are originally intended for the construction of residential dwelling units thereon and shall be restricted for same under the terms and conditions of such restrictions filed separately, unless otherwise noted.

FURTHER, Owner does hereby certify that it is the owner of all property immediately adjacent to the boundaries of the above and foregoing plat of THE WOODLANDS VILLAGE OF ALDEN BRIDGE, SECTION 67 where building setback lines or public utility easements are to be established outside the boundaries of the above and foregoing plat and does hereby make and establish all building setback lines and dedicates to the use of the public forever all public utility easements shown in said adjacent acreage.

IN TESTIMONY WHEREOF, THE WOODLANDS OPERATING COMPANY, L.P., A TEXAS LIMITED PARTNERSHIP acting in its capacity as authorized agent of THE WOODLANDS LAND DEVELOPMENT COMPANY, L.P., A TEXAS LIMITED PARTNERSHIP, has caused these presents to be signed by Michael H. Richmond, its President and Chief Executive Officer, thereunto authorized, this the 7 day of JAN., 1999.

THE WOODLANDS LAND DEVELOPMENT COMPANY, L.P.,  
A Texas Limited Partnership

By: THE WOODLANDS OPERATING COMPANY, L.P.  
A Texas Limited Partnership  
Its Authorized Agent

By: Michael H. Richmond  
Name: Michael H. Richmond  
Title: President and Chief Executive Officer

BUILDING LINE DIAGRAM  
FOR LOT 1 IN BLOCK 2

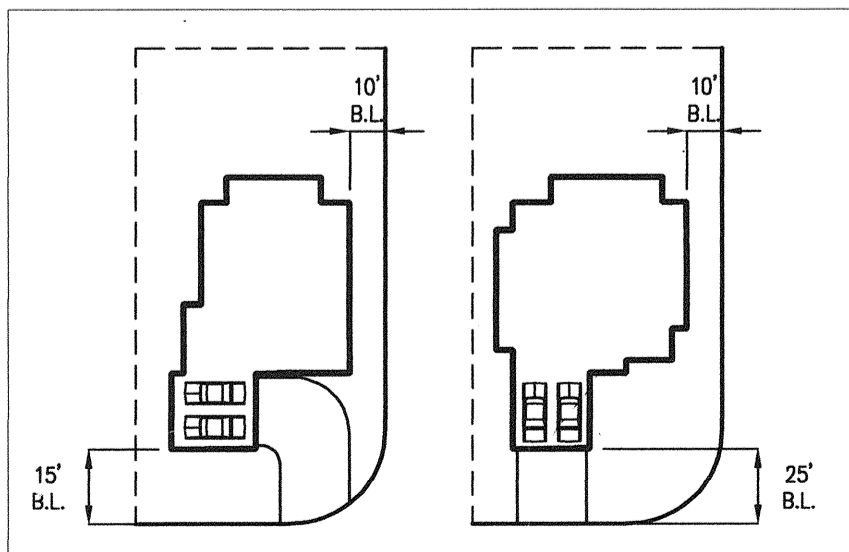

STATE OF TEXAS  
COUNTY OF MONTGOMERY

BEFORE ME, the undersigned authority, on this day personally appeared Michael H. Richmond, President and Chief Executive Officer of THE WOODLANDS OPERATING COMPANY, L.P., a Texas Limited Partnership, Authorized Agent of THE WOODLANDS LAND DEVELOPMENT COMPANY, L.P., a Texas Limited Partnership, known to me to be the person whose name is subscribed to the foregoing instrument and acknowledged to me that he executed the same for the purposes and considerations therein expressed, and in the capacity therein and herein set out, and as an act and deed of said limited partnership.

GIVEN UNDER MY HAND AND SEAL OF OFFICE, this 7 day of JAN., 1999

Delia Gonzales  
Notary Public in and for the State of Texas  
My Commission expires:

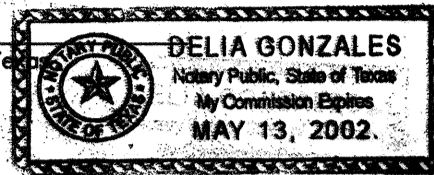

This is to certify that the Houston Planning Commission of the City of Houston, Texas has approved this plat and subdivision of THE WOODLANDS VILLAGE OF ALDEN BRIDGE, SECTION 67 in conformance with the laws of the State of Texas and the ordinances of the City of Houston as shown hereon and authorized the recording of this plat this 20 day of FEB., 1999.

By: M. Marvin Katz  
M. Marvin Katz, Chairman

By: Robert M. Litke  
Robert M. Litke, Secretary



I, Mark J. Mooney, P.E., County Engineer of Montgomery County, Texas, do hereby certify that the plat of this subdivision complies with all of the existing rules and regulations of this office as adopted by the Montgomery County Commissioners' Court.

I further certify that the plat of this subdivision complies with requirements for internal subdivision drainage as adopted by the Commissioners' Court; however, no certification is hereby given as to the effect of drainage from this subdivision on the intercepting drainage artery or parent stream or on any other area of subdivision within the watershed.

Mark J. Mooney  
Mark J. Mooney, P.E.  
Montgomery County Engineer

I, John G. Davidson, an authorized under the laws of the State of Texas to practice the profession of surveying and hereby certify that the above subdivision is true and correct; was prepared from an actual survey of the property made under my supervision on the ground; that the elevation benchmark reflected on the face of the plat was established as required by regulation; that all corners and angle points of the boundaries of the original tract to be subdivided of reference have been marked with iron rods having a diameter of not less than five-eighths of an inch (5/8") and a length of not less than three feet (3'); and that the plat boundary corners have been tied to the nearest survey corner.



John G. Davidson  
John G. Davidson  
Registered Professional Land Surveyor  
Texas Registration No. 1792

APPROVED by the Commissioners' Court of Montgomery County, Texas, this 15 day of March, 1999.

Mike Meador  
Mike Meador  
Commissioner, Precinct 1

Malcolm Purvis  
Malcolm Purvis  
Commissioner, Precinct 2

Alan B. Sadler  
County Judge

Ed Rinehart  
Ed Rinehart  
Commissioner, Precinct 4

Ed Chance  
Commissioner, Precinct 3

I, Mark Turnbull, Clerk of the County Court of Montgomery County, do hereby certify that the within instrument with its certificate of authentication was filed for registration in my office on 03-15-99 at 4:30 o'clock A.M., and duly recorded on March 19, 1999, at 2:26 o'clock P.M., in Cabinet L, Sheet 163-164, of record of Maps for said County.

WITNESS MY HAND AND SEAL OF OFFICE, at Conroe, Montgomery County, Texas, the day and date last above written.

Mark Turnbull  
Mark Turnbull, Clerk of the County Court  
Montgomery County, Texas.

Issued \_\_\_\_\_ By: Alicia Drake  
Deputy

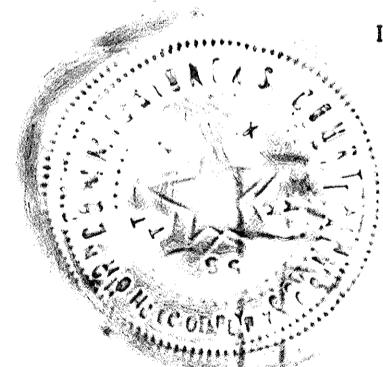

NOTES:

1. This survey has not been tied to the official City of Houston Survey monumentation system in accordance with Ordinance No. 69-1978, because a City survey marker has not been established within 2,000'.
2. B.L. indicates a building line  
U.E. indicates a utility easement  
STM. SWR. ESM'T. indicates a storm sewer easement  
W.L.E. indicates a water line easement  
S.S.E. indicates a sanitary sewer easement  
VOL., PG. indicates Volume, Page  
M.C.M.R. indicates Montgomery County Map Records  
M.C.O.P.R.R.P. indicates Montgomery County Official Public Records of Real Property  
Eas't. indicates Easement  
F.H.E. indicates a Fire hydrant easement  
R.O.S.R. indicates a Restricted Open Space Reserve  
D.E. indicates a Drainage easement.
3. One-foot reserve dedicated for buffer purposes to the public in fee as a buffer separation between the side or end of streets where such streets abut adjacent property, the condition of such dedication being that when the adjacent property is subdivided or re-subdivided in a recorded plat, the one-foot reserve shall thereupon become vested in the public for street right-of-way purposes and the fee title thereto shall revert to and re-vest in the dedicator, his heirs, assigns, or successors.
4. All non-perimeter easements on property lines are centered unless otherwise noted.
5. All bearings are based on the Texas State Plane Coordinate System, South Central Zone.

NUMBER	Delta	Radius	Arc Length
C1	05'44'48"	200.00	20.06
C2	28'13'37"	200.00	98.53
C4	28'35'49"	125.00	62.39
C5	46'50'28"	125.00	102.19
C6	20'36'37"	350.00	125.90
C7	16'31'35"	300.00	86.53
C8	06'40'32"	700.00	81.56
C9	14'33'39"	70.00	175.41
C10	02'57'25"	1235.00	63.74
C11	02'57'25"	1235.00	63.74
C12	87'02'35"	25.00	37.98
C13	87'02'35"	25.00	37.98
C16	87'33'04"	25.00	38.20
C17	92'26'56"	25.00	40.34
C18	78'08'33"	25.00	34.10
C19	78'08'33"	25.00	34.10
C20	04'10'13"	325.00	23.66
C21	74'36'34"	25.00	32.55
C22	74'36'34"	25.00	32.55
C23	100'51'56"	25.00	44.01
C24	98'26'52"	25.00	42.96
C25	21'51'56"	150.00	57.24
C26	55'09'25"	25.00	24.07
C27	55'09'25"	25.00	24.07
C28	03'37'17"	150.00	9.48
C29	90'00'00"	25.00	39.27
C30	97'02'26"	25.00	42.34
C31	05'41'32"	165.00	16.39
C32	117'43'43"	25.00	51.37
C33	19'05'27"	235.00	78.30
C34	69'39'59"	25.00	30.40

NUMBER	BEARING	DISTANCE
L1	S 30'49'17" W	96.24'
L2	S 36'15'20" W	83.02'
L3	S 27'28'37" W	87.54'
L4	S 16'27'00" W	87.63'
L5	N 03'02'04" W	14.31'
L6	S 86'26'48" E	20.78'
L7	N 43'17'16" W	63.24'
L8	S 17'34'33" W	33.85'
L9	S 86'57'56" W	52.81'
L10	N 38'36'21" W	37.92'
L12	S 54'39'02" E	53.87'
L13	N 88'55'37" E	27.13'
L14	S 54'39'02" E	3.87'
L16	S 27'48'23" W	27.38'
L17	S 27'48'23" W	27.38'
L18	N 89'00'59" E	50.16'
L19	N 38'21'11" E	135.22'
L20	N 32'20'52" E	27.85'
L21	N 88'55'37" E	9.43'
L22	S 89'00'59" W	18.04'

# THE WOODLANDS VILLAGE OF ALDEN BRIDGE SECTION 67

A SUBDIVISION OF  
29.15 ACRES  
CONTAINING

3 BLOCKS - 90 LOTS  
& 2.66 AC. IN 4 RESERVES

OUT OF THE DICKINSON GARRETT SURVEY, A-224  
MONTGOMERY COUNTY, TEXAS

OWNER: THE WOODLANDS LAND  
DEVELOPMENT COMPANY, L.P.

2201 TIMBERLOCH PLACE - THE WOODLANDS, TEXAS 77380

ENGINEER: PATE ENGINEERS, INC.

13405 N.W. FRWY., SUITE 300 - HOUSTON, TEXAS 77040

JUNE 1998 JOB No. 31902900

SHEET 1 OF 2

File No. 99021097 Cab. L Sheet 163

PLEASE RETURN TO  
THE WOODLANDS OPERATING COMPANY, L.P.

D = 90°00'00"  
R = 40.00'  
L = 62.83'

ACREAGE  
THE WOODLANDS LAND  
DEVELOPMENT COMPANY, L.P.  
M.C.R.P.R. FILE NO. 9747722

ACREAGE  
THE WOODLANDS LAND  
DEVELOPMENT COMPANY, L.P.  
M.C.R.P.R. FILE NO. 9747722

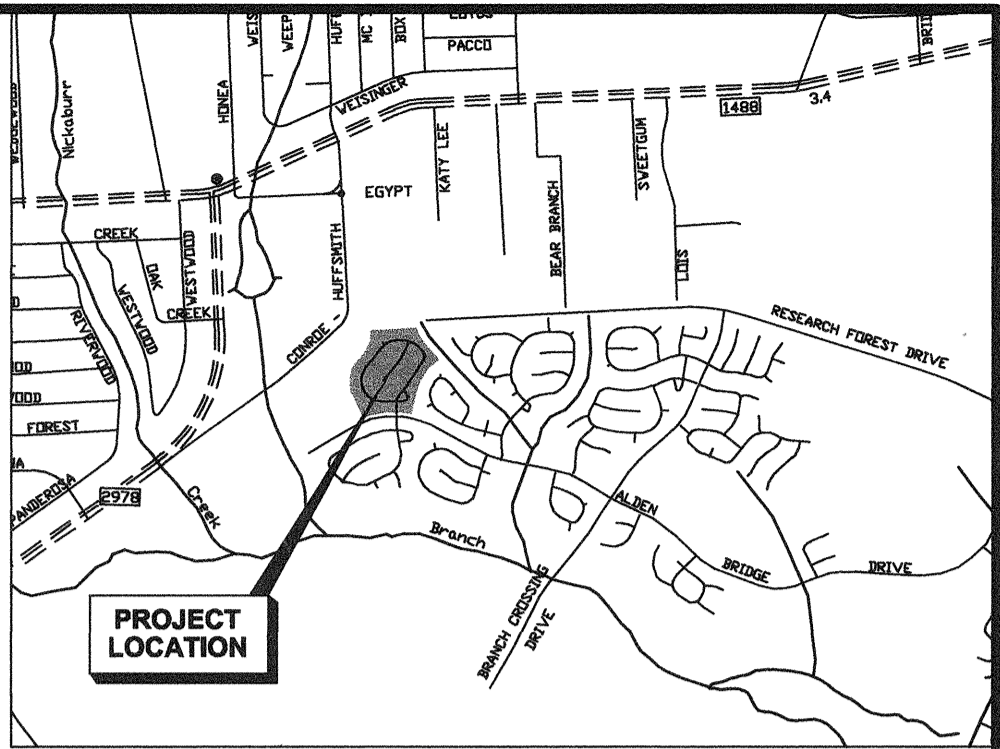

VICINITY MAP

N.T.S.

RESERVE	SQ. FT.	ACRES	TYPE
A	98400	2.26	RESTRICTED FOR OPEN SPACE
B	9700	0.22	RESTRICTED FOR OPEN SPACE
C	4400	0.10	RESTRICTED FOR OPEN SPACE
D	3200	0.07	RESTRICTED FOR DRAINAGE & UTILITY USES

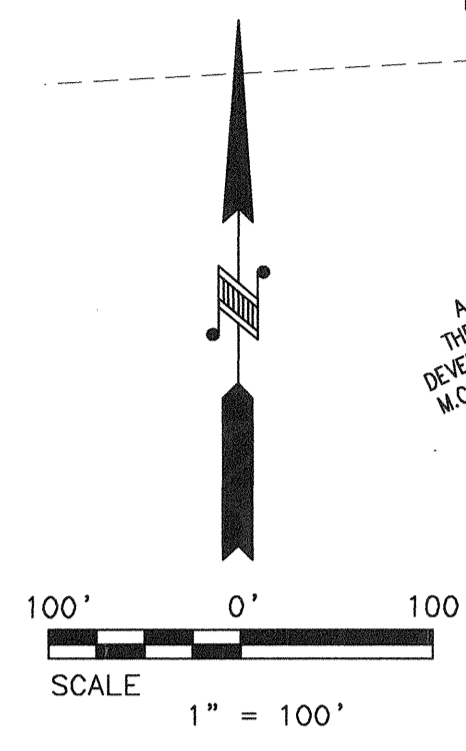

File No. 9921027 Cab. 1 Sheet 1 of 4

PATE ENGINEERS  
D:\31902900\PLAT.DWG 09/08/98 11:20 Randy (MS)

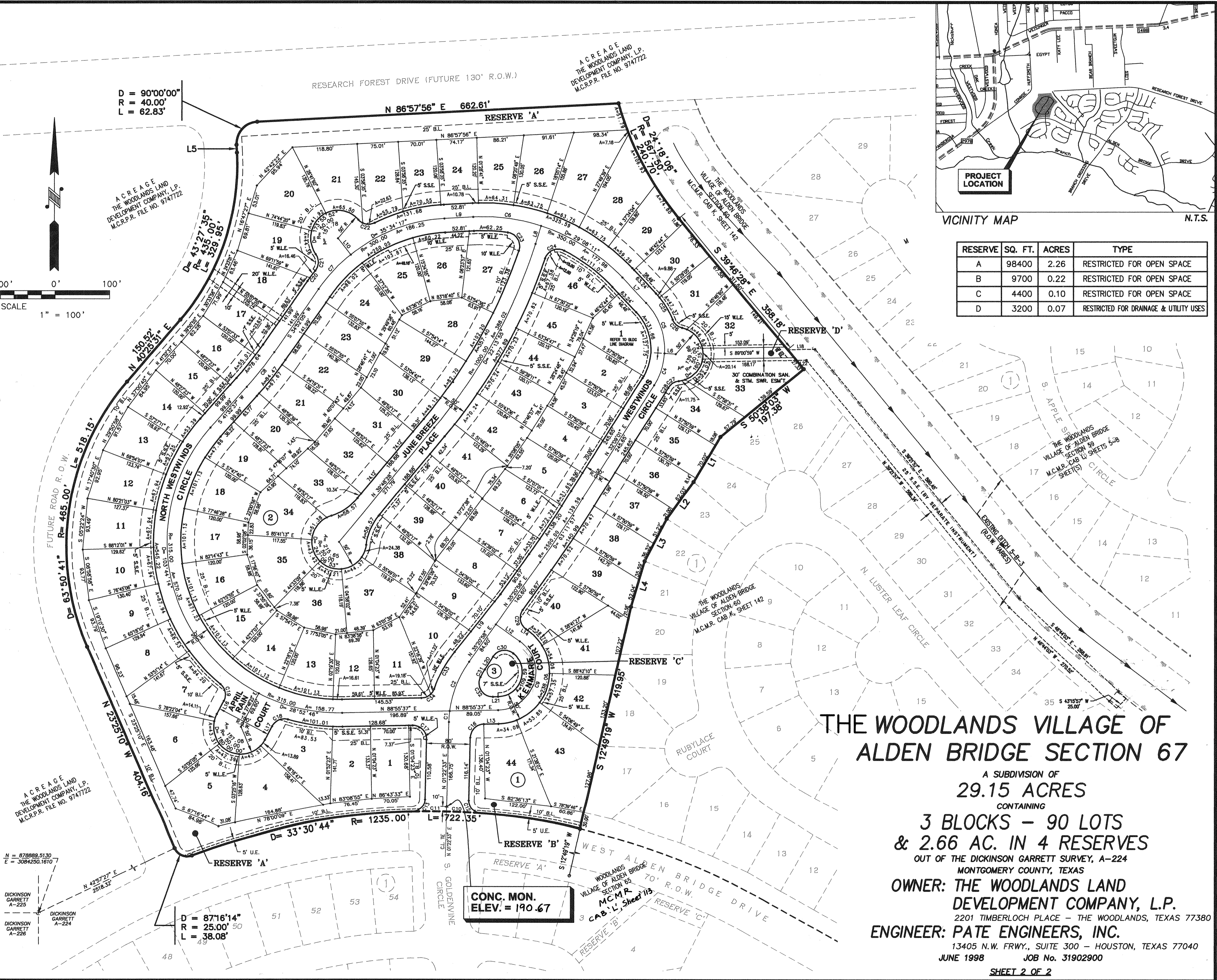

# THE WOODLANDS VILLAGE OF ALDEN BRIDGE SECTION 67

A SUBDIVISION OF  
**29.15 ACRES**

CONTAINING  
**3 BLOCKS - 90 LOTS**  
**& 2.66 AC. IN 4 RESERVES**

OUT OF THE DICKINSON GARRETT SURVEY, A-224  
MONTGOMERY COUNTY, TEXAS

**OWNER: THE WOODLANDS LAND DEVELOPMENT COMPANY, L.P.**

2201 TIMBERLOCH PLACE - THE WOODLANDS, TEXAS 77380

**ENGINEER: PATE ENGINEERS, INC.**

13405 N.W. FRWY., SUITE 300 - HOUSTON, TEXAS 77040  
JUNE 1998 JOB No. 31902900

SHEET 2 OF 2

PLEASE RETURN TO  
THE WOODLANDS OPERATING COMPANY, L.P.