  
 SCALE: 1" = 300'

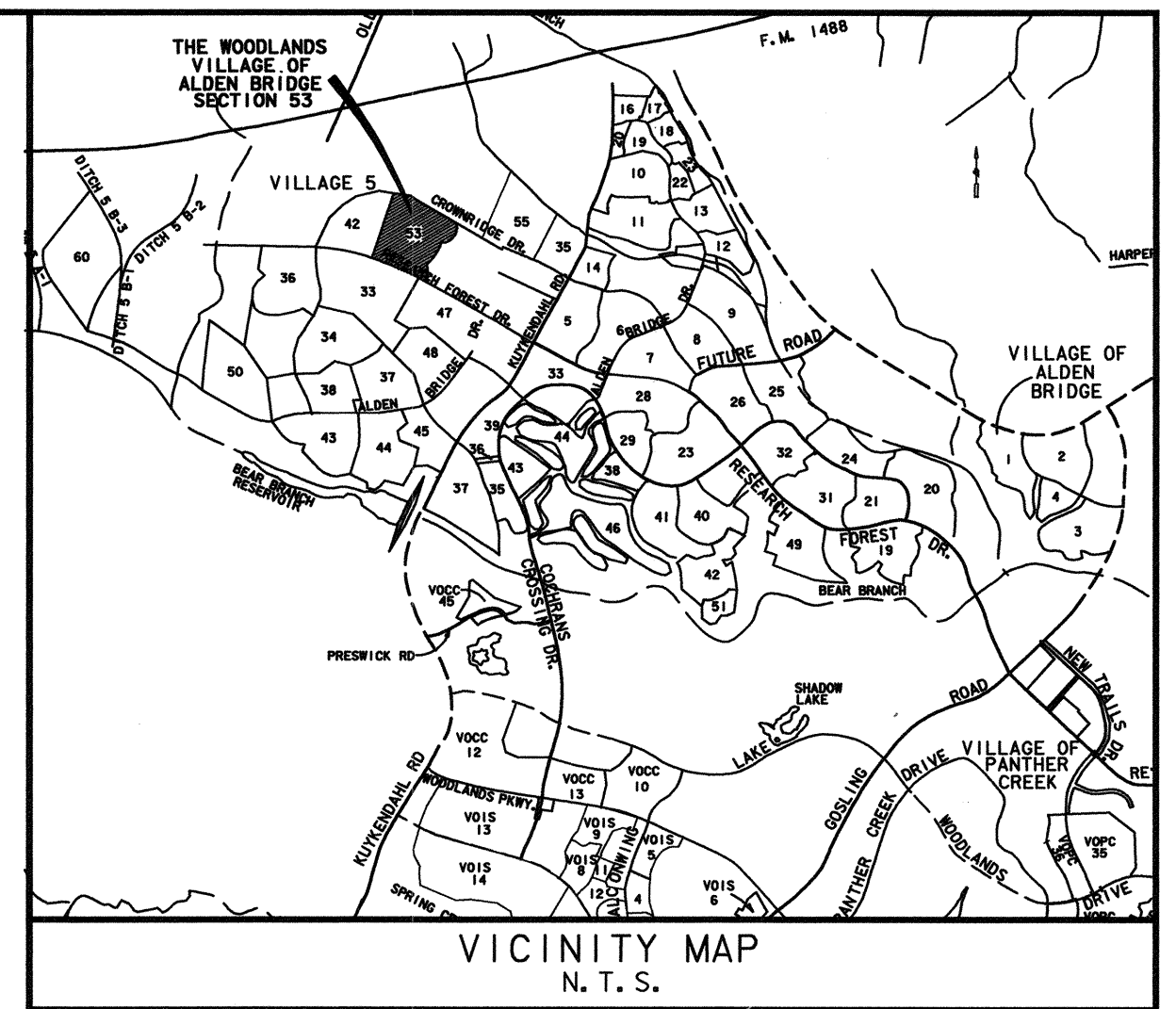
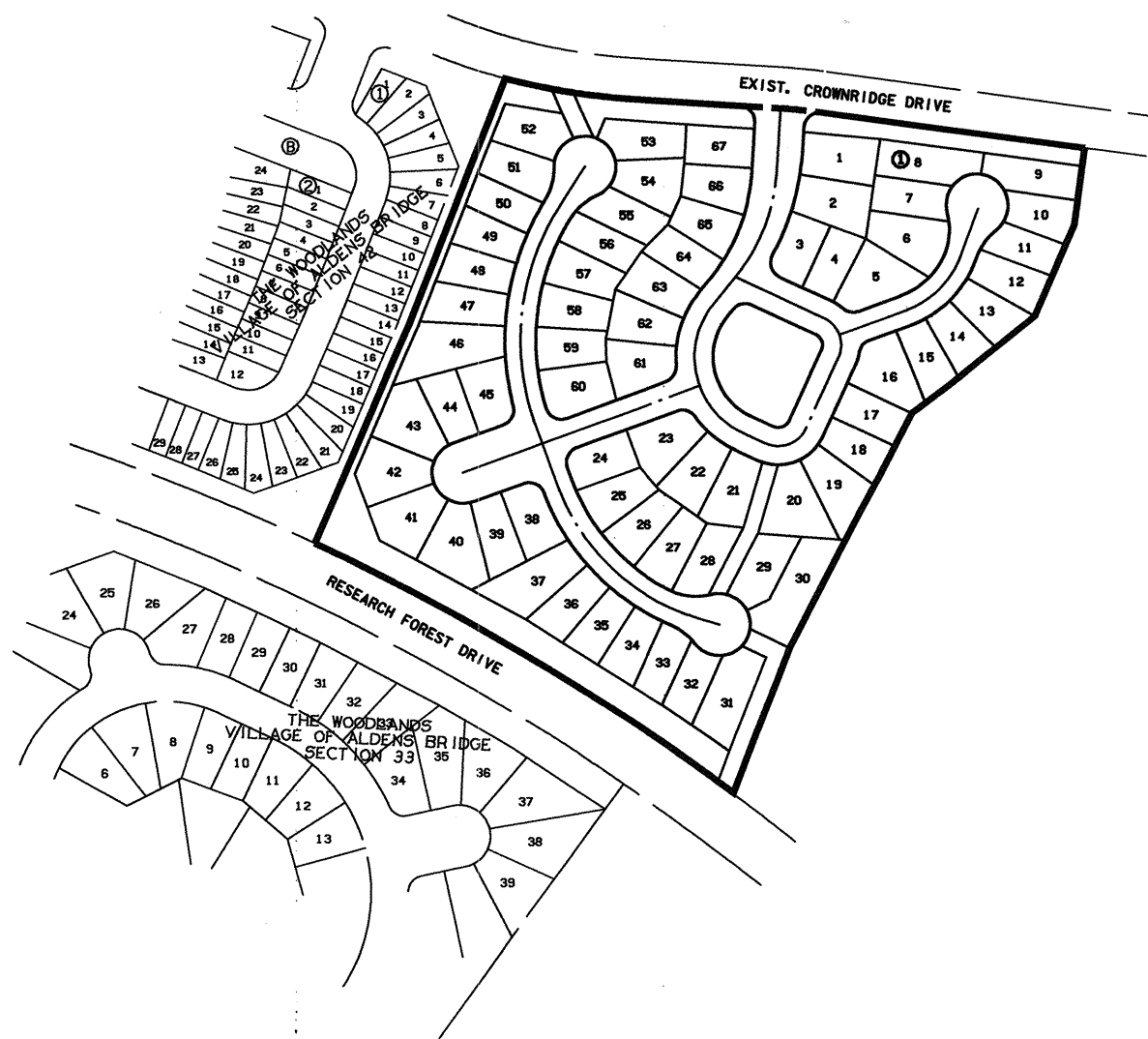

# THE WOODLANDS VILLAGE OF ALDEN BRIDGE SECTION 53

BEING 18.74 ACRES OUT OF THE  
 A. SMITH SURVEY, ABSTRACT 499 (16.86 ACRES) AND THE  
 WILLIAM H. HARRISON SURVEY, ABSTRACT 257 (1.88 ACRES)  
 MONTGOMERY COUNTY, TEXAS

OWNER: THE WOODLANDS LAND DEVELOPMENT COMPANY, L. P.  
 2201 TIMBERLOCH PLACE  
 THE WOODLANDS, TEXAS 77380

1 BLOCK 67 LOTS  
 7 RESERVES  
 2.74 ACRES IN RESERVE

ENGINEER:

DATE: JULY, 1997

**LJA**  
 LJA Engineering & Surveying, Inc.  
 2929 Briarpark Drive Suite 500 Houston, Texas 77042-3703  
 Phone 713.953.5200 Fax 713.953.5026

File# 9802491 Cab. K Sheet 63

STATE OF TEXAS  
COUNTY OF MONTGOMERY

THE WOODLANDS LAND DEVELOPMENT COMPANY, L.P., ACTING HEREIN BY AND THROUGH THE WOODLANDS OPERATING COMPANY, L.P., ITS AUTHORIZED AGENT, ACTING HEREIN BY AND THROUGH ITS PRESIDENT, ROGER L. GALATAS, OWNER (HEREINAFTER REFERRED TO AS "OWNER") OF THE PROPERTY SUBDIVIDED IN THE ABOVE AND FOREGOING MAP OF THE WOODLANDS VILLAGE OF ALDEN BRIDGE SECTION 53 DO HEREBY MAKE SUBDIVISION OF SAID PROPERTY FOR AND ON BEHALF OF SAID THE WOODLANDS LAND DEVELOPMENT COMPANY, L.P. ACCORDING TO THE LINES, STREETS, ALLEYS, PARKS, BUILDING LINES AND EASEMENTS THEREON SHOWN AND DESIGNATE SAID SUBDIVISION AS THE WOODLANDS VILLAGE OF ALDEN BRIDGE SECTION 53, LOCATED IN THE A. SMITH SURVEY, ABSTRACT 499 AND THE WILLIAM H. HARRISON SURVEY, ABSTRACT 257, MONTGOMERY COUNTY, TEXAS AND ON BEHALF OF SAID THE WOODLANDS LAND DEVELOPMENT COMPANY, L.P., AND AS SUCH THE STREETS, ALLEYS, PARKS AND EASEMENTS SHOWN THEREON FOREVER, AND DO HEREBY WAIVE ANY CLAIMS FOR DAMAGES OCCASIONED BY THE ESTABLISHING OF GRADES AS APPROVED FOR THE STREETS AND ALLEYS DEDICATED, OR OCCASIONED BY THE ALTERATION OF THE SURFACE OF ANY PORTION OF STREETS OR ALLEYS TO CONFORM TO SUCH GRADES, AND DO HEREBY BIND MYSELF, MY SUCCESSORS AND ASSIGNS TO WARRANT AND FOREVER DEFEND THE TITLE TO THE LAND SO DEDICATED.

THIS IS TO CERTIFY THAT THE WOODLANDS LAND DEVELOPMENT COMPANY, L.P. ACTING HEREIN BY AND THROUGH THE WOODLANDS OPERATING COMPANY, L.P., ITS AUTHORIZED AGENT, ACTING HEREIN BY AND THROUGH ITS PRESIDENT, ROGER L. GALATAS, OWNER OF THE PROPERTY SUBDIVIDED IN THE ABOVE AND FOREGOING MAP OF THE WOODLANDS VILLAGE OF ALDEN BRIDGE SECTION 53, HAVE COMPLIED OR WILL COMPLY WITH ALL REGULATIONS HERETOFORE ON FILE WITH THE MONTGOMERY COUNTY ENGINEER AND ADOPTED BY THE COMMISSIONERS' COURT OF MONTGOMERY COUNTY, TEXAS.

FURTHER, OWNER HAS DEDICATED AND BY THESE PRESENTS DOES DEDICATE TO THE USE OF THE PUBLIC FOR PUBLIC UTILITY PURPOSES FOREVER UNOBSTRUCTED AERIAL EASEMENTS. THE AERIAL EASEMENTS SHALL EXTEND HORIZONTALLY AN ADDITIONAL ELEVEN FEET, SIX INCHES (11' 6") FOR TEN FEET (10' 0") PERIMETER GROUND EASEMENTS OR FIVE FEET SIX INCHES (5' 6") FOR SIXTEEN FEET (16' 0") PERIMETER GROUND EASEMENTS. FROM A PLANE SIXTEEN FEET (16' 0") ABOVE GROUND LEVEL UPWARD, LOCATED ADJACENT TO AND ADJOINING SAID PUBLIC UTILITY EASEMENTS THAT ARE DESIGNATED WITH AERIAL EASEMENTS (U.E. & A.E.) AS INDICATED AND DEPICTED HEREON, WHEREBY THE AERIAL EASEMENT TOTALS TWENTY ONE FEET, SIX INCHES (21' 6") IN WIDTH.

FURTHER, OWNER HAS DEDICATED AND BY THESE PRESENTS DOES DEDICATE TO THE PUBLIC FOR PUBLIC UTILITY PURPOSES FOREVER UNOBSTRUCTED AERIAL EASEMENTS. THE AERIAL EASEMENTS SHALL EXTEND HORIZONTALLY AN ADDITIONAL TEN FEET (10' 0") FOR TEN FEET (10' 0") BACK-TO-BACK GROUND EASEMENTS OR SEVEN FEET (7' 0") FOR SIXTEEN FEET (16' 0") BACK-TO-BACK GROUND EASEMENTS. FROM A PLANE SIXTEEN FEET (16' 0") ABOVE GROUND LEVEL UPWARD, LOCATED ADJACENT TO BOTH SIDES AND ADJOINING SAID PUBLIC UTILITY EASEMENTS THAT ARE DESIGNATED WITH AERIAL EASEMENTS (U.E. & A.E.) AS INDICATED AND DEPICTED HEREON, WHEREBY THE AERIAL EASEMENT TOTALS THIRTY FEET (30' 0") IN WIDTH.

FURTHER, OWNER DOES HEREBY DEDICATE FOREVER TO THE PUBLIC A STRIP OF LAND A MINIMUM FIFTEEN (15' - 0") FEET WIDE ON EACH SIDE OF THE CENTERLINE, OF ANY AND OF ALL GULLIES, RAVINES, DRAWS, SLOUGHS, OR OTHER NATURAL DRAINAGE COURSES LOCATED IN THE SAID SUBDIVISION, AS EASEMENTS FOR DRAINAGE PURPOSES, GIVING MONTGOMERY COUNTY AND/OR ANY OTHER PUBLIC AGENCY THE RIGHT TO ENTER UPON SAID EASEMENTS AT ANY AND ALL TIMES FOR THE PURPOSE OF CONSTRUCTING AND/OR MAINTAINING DRAINAGE WORK AND/OR STRUCTURES.

FURTHER, ALL OF THE PROPERTY SUBDIVIDED IN THE ABOVE AND FOREGOING MAP SHALL BE RESTRICTED IN ITS USE, WHICH RESTRICTIONS SHALL RUN WITH THE TITLE TO THE PROPERTY, AND SHALL BE ENFORCEABLE, AT THE OPTION OF MONTGOMERY COUNTY, BY MONTGOMERY COUNTY OR ANY CITIZEN THEREOF, BY INJUNCTION, AS FOLLOWS:

1. THAT DRAINAGE OF SEPTIC TANKS INTO ROAD, STREET, ALLEY, OR OTHER PUBLIC DITCHES, EITHER DIRECTLY OR INDIRECTLY, IS STRICTLY PROHIBITED.
2. DRAINAGE STRUCTURES UNDER PRIVATE DRIVEWAYS SHALL HAVE A NET DRAINAGE OPENING AREA OF SUFFICIENT SIZE TO PERMIT THE FREE FLOW OF WATER WITHOUT BACKWATER, AND SHALL BE A MINIMUM OF ONE AND THREE QUARTERS (1-3/4) SQUARE FEET (18" DIAMETER PIPE CULVERT).

FURTHER, OWNER DOES HEREBY CERTIFY THAT IT IS THE OWNER OF ALL PROPERTY IMMEDIATELY ADJACENT TO THE BOUNDARIES OF THE ABOVE AND FOREGOING PLAT OF THE WOODLANDS VILLAGE OF ALDEN BRIDGE SECTION 53 WHERE BUILDING SETBACK LINES OR PUBLIC UTILITY EASEMENTS ARE TO BE ESTABLISHED OUTSIDE THE BOUNDARIES OF THE ABOVE AND FOREGOING PLAT AND DOES HEREBY MAKE AND ESTABLISH ALL BUILDING SETBACK LINES AND DEDICATES TO THE USE OF THE PUBLIC FOREVER ALL PUBLIC UTILITY EASEMENTS SHOWN IN SAID ADJACENT ACREAGE.

IN TESTIMONY WHEREOF THE WOODLANDS OPERATING COMPANY, L.P., A TEXAS LIMITED PARTNERSHIP ACTING IN ITS CAPACITY AS AUTHORIZED AGENT OF THE WOODLANDS LAND DEVELOPMENT COMPANY, L.P., A TEXAS LIMITED PARTNERSHIP, HAS CAUSED THESE PRESENTS TO BE SIGNED BY ROGER L. GALATAS, ITS PRESIDENT, THEREUNTO AUTHORIZED, THIS THE 10 DAY OF October, 1997.

THE WOODLANDS LAND DEVELOPMENT COMPANY, L.P.  
A TEXAS LIMITED PARTNERSHIP

BY: THE WOODLANDS OPERATING COMPANY, L.P.  
A TEXAS LIMITED PARTNERSHIP,  
ITS AUTHORIZED AGENT

BY: Roger L. Galatas  
NAME: ROGER L. GALATAS  
TITLE: PRESIDENT

STATE OF TEXAS  
COUNTY OF MONTGOMERY

BEFORE ME, THE UNDERSIGNED AUTHORITY, ON THIS DAY PERSONALLY APPEARED ROGER L. GALATAS, PRESIDENT OF THE WOODLANDS OPERATING COMPANY, L.P., A TEXAS LIMITED PARTNERSHIP, AUTHORIZED AGENT OF THE WOODLANDS LAND DEVELOPMENT COMPANY, L.P., A TEXAS LIMITED PARTNERSHIP, KNOWN TO ME TO BE THE PERSON WHOSE NAME IS SUBSCRIBED TO THE FOREGOING INSTRUMENT AND ACKNOWLEDGED TO ME THAT HE EXECUTED THE SAME FOR THE PURPOSES AND CONSIDERATIONS THEREIN EXPRESSED, AND IN THE CAPACITY THEREIN AND HEREIN SET OUT AND AS AN ACT AND DEED OF SAID LIMITED PARTNERSHIP.

GIVEN UNDER MY HAND AND SEAL OF OFFICE, THIS 10th DAY OF October, 1997.

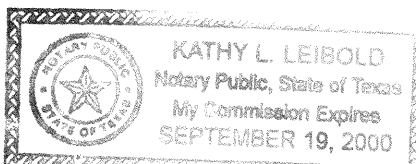

Kathy L. Leibold  
NOTARY PUBLIC IN AND FOR THE STATE OF TEXAS

MY COMMISSION EXPIRES:

File # 9802491 Cab. K Sheet 64

I, JOHN G. DAVIDSON, AM REGISTERED UNDER THE LAWS OF THE STATE OF TEXAS TO PRACTICE THE PROFESSION OF SURVEYING AND HEREBY CERTIFY THAT THE ABOVE SUBDIVISION IS TRUE AND CORRECT, WAS PREPARED FROM AN ACTUAL SURVEY OF THE PROPERTY MADE UNDER MY SUPERVISION ON THE GROUND, THAT THE ELEVATION BENCHMARK REFLECTED ON THE FACE OF THE PLAT WAS ESTABLISHED AS REQUIRED BY REGULATION, THAT ALL CORNERS AND ANGLE POINTS OF THE BOUNDARIES OF THE ORIGINAL TRACT TO BE SUBDIVIDED OF REFERENCE HAVE BEEN MARKED WITH IRON RODS HAVING A DIAMETER OF NOT LESS THAN FIVE-EIGHTHS OF AN INCH (5/8") AND A LENGTH OF NOT LESS THAN THREE FEET (3'), AND THAT THE PLAT BOUNDARY CORNERS HAVE BEEN TIED TO THE NEAREST SURVEY CORNER.

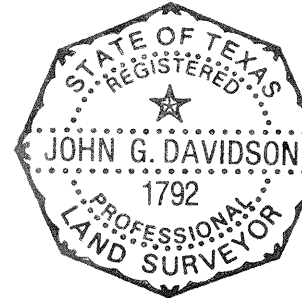

John G. Davidson  
PRINT NAME: JOHN G. DAVIDSON  
TEXAS REGISTRATION: 1792

THIS IS TO CERTIFY THAT THE HOUSTON PLANNING COMMISSION OF THE CITY OF HOUSTON, TEXAS HAS APPROVED THIS PLAT AND SUBDIVISION OF THE WOODLANDS VILLAGE OF ALDEN BRIDGE SECTION 53 IN CONFORMANCE WITH THE LAWS OF THE STATE OF TEXAS AND THE ORDINANCES OF THE CITY OF HOUSTON AS SHOWN HEREON AND AUTHORIZED THE RECORDING OF THIS PLAT, THIS 10th DAY OF December, 1997.

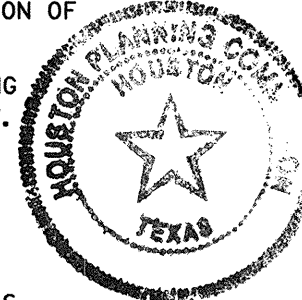

BY: M. Marvin Katz ATTEST: Robert M. Litke  
M. MARVIN KATZ, ROBERT M. LITKE,  
CHAIRMAN SECRETARY

I, J.D. BLANTON, COUNTY ENGINEER OF MONTGOMERY COUNTY, TEXAS, DO HEREBY CERTIFY THAT THE PLAT OF THIS SUBDIVISION COMPLIES WITH ALL OF THE EXISTING RULES AND REGULATIONS OF THIS OFFICE AS ADOPTED BY THE MONTGOMERY COUNTY COMMISSIONERS' COURT.

I FURTHER CERTIFY THAT THE PLAT OF THIS SUBDIVISION COMPLIES WITH REQUIREMENTS FOR INTERNAL SUBDIVISION DRAINAGE AS ADOPTED BY THE MONTGOMERY COUNTY COMMISSIONERS' COURT, HOWEVER, NO CERTIFICATION IS HEREBY GIVEN AS TO THE EFFECT OF DRAINAGE FROM THIS SUBDIVISION TO THE INTERCEPTING DRAINAGE ARTERY OR PARENT STREAM OR ANY OTHER AREA OF SUBDIVISION WITHIN THE WATERSHED.

J.D. Blanton  
J. D. BLANTON  
MONTGOMERY COUNTY ENGINEER

APPROVED BY THE COMMISSIONERS' COURT OF MONTGOMERY COUNTY, TEXAS, THIS 10 DAY OF January, 1998.

Mike Meador Malcolm Purvis  
MIKE MEADOR MALCOLM PURVIS  
COMMISSIONER, PRECINCT 1 COMMISSIONER, PRECINCT 2

Alan B. Sadler  
ALAN B. SADLER  
COUNTY JUDGE

Ed Chance Jim Simmons  
ED CHANCE JIM SIMMONS  
COMMISSIONER, PRECINCT 3 COMMISSIONER, PRECINCT 4

THE STATE OF TEXAS  
COUNTY OF MONTGOMERY

I, MARK TURNBULL, CLERK OF THE COUNTY COURT OF MONTGOMERY COUNTY, TEXAS, DO HEREBY CERTIFY THAT THE WITHIN INSTRUMENT WITH ITS CERTIFICATE OF AUTHENTICATION WAS FILED FOR REGISTRATION IN MY OFFICE ON January 12, 1998 AT 9:30 O' CLOCK A.M. AND DULY RECORDED ON January 14, 1998 AT 8:16 O' CLOCK A.M. IN CABINET K, SHEET 63-66, OF RECORD OF Maps FOR SAID COUNTY.

WITNESS MY HAND AND SEAL OF OFFICE, AT CONROE, MONTGOMERY COUNTY, TEXAS, THE DAY AND DATE LAST ABOVE WRITTEN.

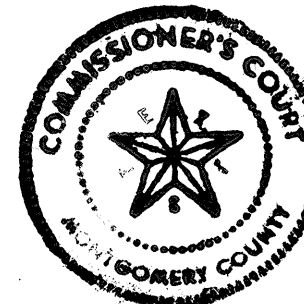

Mark Turnbull  
MARK TURNBULL, CLERK, COUNTY COURT  
MONTGOMERY COUNTY, TEXAS

BY: \_\_\_\_\_

FILED FOR RECORD  
98 JAN 14 AM 8:16  
MARK TURNBULL, CO. CLERK  
MONTGOMERY COUNTY, TEXAS  
\_\_\_\_\_  
DEPUTY

OWNER: THE WOODLANDS LAND DEVELOPMENT COMPANY, L.P.  
2201 TIMBERLOCH PLACE  
THE WOODLANDS, TEXAS 77380

THE WOODLANDS  
VILLAGE OF  
ALDEN BRIDGE  
SECTION 53  
SHEET 2 OF 4

RESTRICTED RESERVE 'D'  
1.246 AC. 54,291 SQ. FT.  
RESTRICTED FOR OPEN SPACE

RESTRICTED RESERVE 'C'  
0.06 AC. 2,431 SQ. FT.  
RESTRICTED FOR DRAINAGE &  
MUNICIPAL UTILITIES

RESTRICTED RESERVE 'B'  
0.24 AC. 10,489 SQ. FT.  
RESTRICTED FOR OPEN SPACE

RESTRICTED RESERVE 'A'  
0.32 AC. 13,803 SQ. FT.  
RESTRICTED FOR OPEN SPACE

ACREAGE

THE WOODLANDS  
VILLAGE OF ALDEN BRIDGE  
SECTION 31  
CABINET M.C.M.R.



100 50 0 100 200  
SCALE: 1"=100'

P. O. B.  
X = 3095702.9088  
Y = 881986.9020

ACREAGE

ACREAGE

RESTRICTED RESERVE 'F'  
0.13 AC. 5,705 SQ. FT.  
RESTRICTED FOR DRAINAGE &  
MUNICIPAL UTILITIES

RESTRICTED RESERVE 'E'  
0.20 AC. 8,669 SQ. FT.  
RESTRICTED FOR DRAINAGE &  
MUNICIPAL UTILITIES

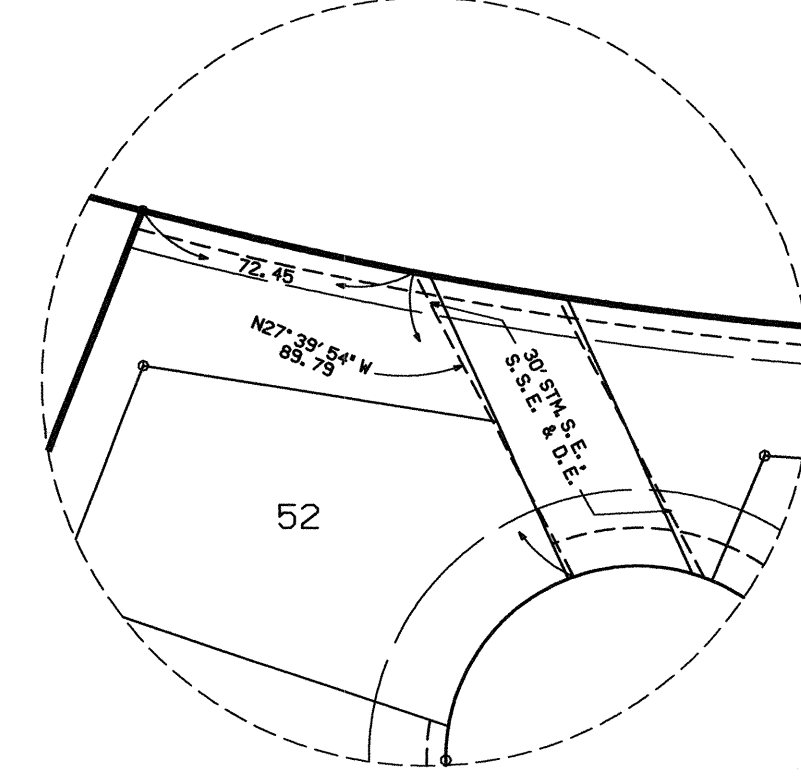

INSET 'A'

OWNER: THE WOODLANDS LAND DEVELOPMENT COMPANY, L.P.  
2201 TIMBERLOCH PLACE  
THE WOODLANDS, TEXAS 77380

THE WOODLANDS  
VILLAGE OF  
ALDEN BRIDGE  
SECTION 53  
SHEET 3 OF 4

File# 9802491 Cab. K Sheet 65

GENERAL NOTES

1. D. E. INDICATES DRAINAGE EASEMENT. DRAINAGE EASEMENT SHALL HEREBY BE RESTRICTED TO KEEP CLEAR OF FENCES, BUILDING, PLANTING AND OTHER OBSTRUCTIONS TO THE OPERATIONS AND MAINTENANCE OF THE DRAINAGE FACILITY.
2. B. L. INDICATES BUILDING LINES.
3. S. S. E. INDICATES SANITARY SEWER EASEMENT.
4. STM. S. E. INDICATES STORM SEWER EASEMENT. MAINTAIN DRAINAGE BENEATH FENCES (MIN. 5' SQ. FT.) AND AROUND OTHER OBSTRUCTIONS THAT WOULD OTHERWISE INTERRUPT THE OPERATIONS AND MAINTENANCE OF THE DRAINAGE FACILITY.
5. 10' D. E. INDICATES DRAINAGE EASEMENT FOR SIDE LOTS. MAINTAIN DRAINAGE BENEATH FENCES (MIN. 5' SQ. FT.) AND AROUND OTHER OBSTRUCTIONS THAT WOULD OTHERWISE INTERRUPT THE OPERATIONS AND MAINTENANCE OF THE DRAINAGE FACILITY.
6. W. L. E. INDICATES WATER LINE EASEMENT.
7. U. E. INDICATES UTILITY EASEMENT.
8. ALL UTILITY EASEMENTS EXTEND EQUAL DISTANCE EITHER SIDE OF PROPERTY LINES UNLESS OTHERWISE NOTED.
9. 1' ONE-FOOT RESERVE DEDICATED TO THE PUBLIC IN FEE AS A BUFFER SEPARATION BETWEEN THE SIDE OR END OF STREETS WHERE SUCH STREETS ABUT ADJACENT ACREAGE TRACTS. THE CONDITION OF SUCH DEDICATION BEING THAT WHEN THE ADJACENT PROPERTY IS SUBDIVIDED IN A RECORDED PLAT, THE ONE-FOOT RESERVE SHALL THEREUPON BECOME VESTED IN THE PUBLIC FOR STREET RIGHT-OF-WAY PURPOSES AND THE FEE TITLE THERETO SHALL REVERT TO AND REVEST IN THE DEDICATOR, HIS HEIRS, ASSIGNS OR SUCCESSORS.
10. THIS SURVEY IS NOT TIED INTO THE OFFICIAL CITY OF HOUSTON SURVEY SYSTEM IN COMPLIANCE WITH ORDINANCE NO. 69-1978, BECAUSE A CITY OF HOUSTON SURVEY MARKER HAS NOT BEEN ESTABLISHED WITHIN 2,000 FEET OF THIS PROPERTY.
11. ALL BEARINGS REFERENCED TO THE TEXAS STATE PLANE COORDINATE SYSTEM SOUTH CENTRAL ZONE.
12. LOTS ADJACENT TO RESTRICTED OPEN SPACE RESERVES ARE DENIED DIRECT DRIVEWAY ACCESS ACROSS SAID RESERVES.
13. R. O. S. R. INDICATES OPEN SPACE RESERVE.

CURVE TABLE						
CURVE	RADIUS	TANGENT	CHORD	ARC	DELTA	CHORD BEARING
1	1035.00	102.53	204.06	204.39	11°18'53"	S-81-00-48-E
2	715.00	26.94	53.84	53.86	04°18'56"	S-84-28-05-E
3	4065.00	395.01	786.32	787.55	11°06'02"	N-59-24-59-W
4	25.00	26.96	36.66	41.15	94°18'58"	S-50-31-55-W
5	400.00	90.80	177.09	178.57	25°34'43"	S-16-09-48-W
6	25.00	26.91	36.63	41.11	94°13'17"	S-18-09-29-E
7	25.00	19.47	30.73	33.09	75°50'07"	S-76-48-49-W
8	105.00	134.79	165.67	190.89	104°09'54"	S-13-11-11-E
9	20.00	19.95	28.25	31.37	89°51'53"	N-69-39-49-E
10	20.00	20.00	28.28	31.42	89°59'58"	N-20-16-08-W
11	80.00	11.64	23.05	23.13	16°33'47"	S-56-59-14-E
12	25.00	14.89	25.59	26.86	61°33'47"	S-79-29-15-E
13	125.00	49.89	92.68	94.94	43°31'07"	N-47-58-18-E
14	100.00	37.89	70.86	72.43	41°29'59"	N-05-27-45-E
15	50.00	*	83.43	215.46	246°54'17"	S-71-50-07-E
16	100.00	28.06	54.03	54.71	31°20'46"	S-35-56-39-W
17	175.00	80.60	146.42	151.07	49°27'37"	S-45-00-03-W
18	25.00	14.89	25.59	26.86	61°33'47"	S-38-56-58-W
19	80.00	11.64	23.05	23.13	16°33'47"	S-16-26-57-W
20	80.00	79.95	113.10	126.62	89°57'58"	S-69-42-51-W
21	185.00	43.81	84.59	85.65	25°44'33"	N-50-25-52-W
22	25.00	19.09	30.35	32.61	74°44'33"	N-72-53-51-W
23	25.00	25.00	35.36	39.27	90°00'01"	S-24-43-52-W
24	320.00	124.64	232.28	237.71	42°33'41"	S-41-32-58-E
25	100.00	38.03	71.10	72.69	41°38'47"	S-83-39-12-E
26	50.00	*	83.77	214.86	246°12'32"	S-18-37-41-W
27	100.00	25.97	50.27	50.82	29°07'04"	N-52-49-35-W
28	370.00	161.21	295.58	304.06	47°05'07"	N-43-50-33-W
29	25.00	24.99	35.35	39.26	89°58'08"	N-65-17-04-W
30	50.00	*	100.00	157.08	180°00'00"	N-20-16-08-W
31	25.00	22.63	33.56	36.79	84°18'53"	N-27-34-26-E
32	425.00	182.51	335.41	344.78	46°28'54"	N-08-39-26-E
33	100.00	29.21	56.07	56.83	32°33'46"	N-15-37-00-E
34	50.00	*	83.36	215.61	247°04'02"	S-57-07-53-E
35	100.00	31.90	60.79	61.76	35°23'14"	S-48-42-32-W
36	375.00	167.26	305.51	314.67	48°04'38"	S-06-58-35-W
37	25.00	26.44	36.33	40.67	93°12'24"	S-63-39-56-E
38	25.00	19.09	30.35	32.61	74°44'33"	N-32-21-36-E
39	185.00	66.51	123.37	126.44	43°54'27"	N-16-56-33-E
40	300.00	96.10	183.03	185.99	35°31'20"	N-21-08-06-E
41	25.00	25.00	35.36	39.27	90°00'00"	N-41-37-34-W
42	25.00	26.96	36.66	41.15	94°18'58"	N-50-31-55-E
43	25.00	25.00	35.36	39.27	90°00'00"	S-41-37-34-E
44	50.00	2.69	5.37	5.37	06°09'21"	N-70-24-10-W
45	50.00	15.72	30.00	30.47	34°54'56"	N-25-18-30-E
46	20.00	20.00	28.28	31.42	89°59'58"	S-20-16-08-E
47	20.00	19.95	28.25	31.37	89°51'53"	S-69-39-49-W
48	105.00	134.79	165.67	190.89	104°09'54"	N-13-11-11-W
49	25.00	19.47	30.73	33.09	75°50'07"	N-76-48-49-E
50	80.00	12.74	25.17	25.27	18°05'59"	S-80-40-15-E
51	50.00	12.53	24.31	24.56	28°08'42"	S-89-35-48-W
52	100.00	2.29	4.57	4.57	02°37'06"	S-76-49-58-W
53	135.00	76.64	133.29	139.40	59°09'54"	N-09-18-49-E
54	300.00	96.10	183.03	186.00	35°31'21"	N-21-08-06-E
55	50.00	50.00	70.71	78.54	90°00'00"	S-20-16-08-E
56	50.00	49.95	70.68	78.49	89°58'45"	S-69-42-15-W
57	135.00	55.92	103.32	106.03	45°00'00"	N-42-46-08-W
58	150.00	69.09	125.50	128.49	49°27'37"	N-45-00-03-E
59	345.00	174.08	310.83	322.44	53°32'55"	N-47-02-35-W
60	400.00	200.41	358.35	371.57	53°13'23"	N-06-20-33-E
61	1035.00	45.80	91.51	91.54	05°04'04"	S-84-08-13-E
62	1035.00	18.07	36.13	36.13	02°00'00"	S-80-36-11-E
63	50.00	17.11	32.38	32.97	37°46'54"	S-87-37-42-W
64	1035.00	38.38	76.70	75.72	04°14'50"	N-77-28-46-W
65	4065.00	379.36	755.44	755.53	10°39'48"	S-59-38-06-E
66	4065.00	15.51	31.02	31.02	00°26'14"	N-54-05-05-W

LINE TABLE		
LINE	BEARING	DISTANCE
1	S-53-15-21-W	94.22
2	S-27-08-32-W	103.09
3	S-28-06-35-W	76.70
4	S-86-37-34-E	71.13
5	S-82-18-36-E	6.36
6	S-03-22-26-W	36.80
7	S-44-10-22-W	63.53
8	S-38-53-46-W	14.93
9	S-65-16-08-E	39.26
10	N-65-16-08-W	113.12
11	N-44-10-22-E	63.63
12	S-65-16-08-E	91.95
13	N-69-43-52-E	71.99
14	S-20-16-14-W	6.61
15	S-69-43-52-W	71.99
16	N-65-16-08-W	39.26
17	S-20-16-08-E	24.79
18	S-69-43-52-W	86.60
19	N-69-43-52-E	88.81
20	N-38-53-47-E	31.77
21	N-03-22-26-E	80.11
22	S-03-22-26-W	28.44
23	S-20-16-15-W	6.61
24	S-69-43-52-W	26.75
25	S-53-15-21-W	27.68
26	S-28-06-35-W	26.72
27	N-85-50-02-W	9.02
28	N-54-44-07-W	18.59
29	N-40-46-04-W	7.22
30	N-54-44-07-W	47.06
31	N-40-46-04-W	47.65
32	N-20-41-43-W	65.00
33	N-54-44-07-W	47.66
34	N-83-13-27-W	59.58
35	S-62-57-45-W	41.29
36	N-21-21-50-E	10.67
37	S-03-22-26-W	9.77
38	S-24-49-04-W	13.37
39	S-44-58-18-W	13.28
40	S-10-38-14-W	16.71
41	S-10-38-14-W	13.01
42	N-38-53-47-E	7.54
43	N-38-53-47-E	24.24
44	N-03-22-26-E	4.78
45	S-03-22-26-W	65.00
46	S-05-36-18-W	52.13
47	S-24-49-04-W	49.37
48	S-44-58-18-W	61.38
49	S-01-26-22-E	37.69
50	S-14-36-31-E	62.88
51	N-03-22-26-E	8.37
52	S-07-41-24-W	30.00
53	S-03-22-26-W	10.33
54	N-86-27-32-W	109.98
55	S-22-40-30-W	35.44
56	N-24-27-42-W	44.65
57	N-80-52-44-W	93.36
58	S-61-35-30-E	99.54
59	N-64-41-30-W	43.20
60	S-64-41-30-E	71.10
61	S-65-16-08-E	113.12
62	N-38-53-46-E	14.93
63	N-15-55-54-E	110.92
64	S-27-18-54-W	110.82
65	N-38-53-46-E	58.59
66	N-03-22-26-E	100.71
67	N-20-16-15-E	84.64
68	N-69-43-42-W	3.11
69	N-73-49-03-W	34.56
70	N-20-16-08-W	105.21
71	N-32-57-14-E	73.37
72	N-24-27-42-W	79.14
73	N-21-10-00-E	51.05
74	N-24-27-42-W	42.44
75	N-24-27-42-W	87.09

RESERVES			
RESERVE	ACREAGE	SQ. FT.	TYPE
A	0.32	13,803	RESTRICTED FOR OPEN SPACE USE ONLY
B	0.00	00,000	RESTRICTED FOR OPEN SPACE USE ONLY
C	0.00	00,000	RESTRICTED FOR DRAINAGE & MUNICIPAL UTILITIES
D	0.00	0,000	RESTRICTED FOR OPEN SPACE USE ONLY
E	0.00	00,000	RESTRICTED FOR DRAINAGE & MUNICIPAL UTILITIES
F	0.13	5,705	RESTRICTED FOR DRAINAGE & MUNICIPAL UTILITIES
G	0.55	24,055	UNRESTRICTED
TOTAL	2.74	119,444	-----

I:\PROJDSK\ALDEN\FPAB53.DGN  
10/29/97 18:37:45

File# 9802491 Cab. K Sheet 66

OWNER: THE WOODLANDS LAND DEVELOPMENT COMPANY, L.P.  
2201 TIMBERLOCH PLACE  
THE WOODLANDS, TEXAS 77380

THE WOODLANDS  
VILLAGE OF  
ALDEN BRIDGE  
SECTION 53  
SHEET 4 OF 4