

THE WOODLANDS VILLAGE OF ALDEN BRIDGE SECTION 38

BEING 20.66 ACRES OUT OF THE
A. SMITH SURVEY, ABSTRACT 499
MONTGOMERY COUNTY, TEXAS

OWNER: THE WOODLANDS CORPORATION
2201 TIMBERLOCH PLACE
THE WOODLANDS, TEXAS 77380

2 BLOCKS 68 LOTS
2 RESERVES
1.40 ACRES IN RESERVE

ENGINEER:

LJA Land Development Engineering
& Surveying, Inc.
2929 Briarpark Drive, Suite 500, Houston, Texas 77042-3703
Phone 713.953.5200 Fax 713.953.5026

DATE: AUGUST, 1996

File # 9718445 Cab. I Sheet 193

SHEET 1 OF 4

STATE OF TEXAS
COUNTY OF MONTGOMERY

I, ROGER L. GALATAS, PRESIDENT OF THE WOODLANDS CORPORATION OWNER (HEREINAFTER REFERRED TO AS 'OWNER') OF THE PROPERTY SUBDIVIDED IN THE ABOVE AND FOREGOING MAP OF THE WOODLANDS VILLAGE OF ALDEN BRIDGE SECTION 38 DO HEREBY MAKE SUBDIVISION OF SAID PROPERTY FOR AND ON BEHALF OF SAID THE WOODLANDS CORPORATION, ACCORDING TO THE LINES, STREETS, LOTS, ALLEYS PARKS, BUILDING LINES AND EASEMENTS THEREON SHOWN AND DESIGNATE SAID SUBDIVISION AS THE WOODLANDS VILLAGE OF ALDEN BRIDGE SECTION 38, LOCATED IN THE A. SMITH SURVEY, ABSTRACT 499, MONTGOMERY COUNTY, TEXAS AND ON BEHALF OF SAID THE WOODLANDS CORPORATION, AND DEDICATE TO PUBLIC USE, AS SUCH, THE STREETS, ALLEYS, PARKS AND EASEMENTS SHOWN THEREON FOREVER, AND DO HEREBY WAIVE ANY CLAIMS FOR DAMAGES OCCASIONED BY THE ESTABLISHING OF GRADES AS APPROVED FOR THE STREETS AND ALLEYS DEDICATED, OR OCCASIONED BY THE ALTERATION OF THE SURFACE OF ANY PORTION OF STREETS OR ALLEYS TO CONFORM TO SUCH GRADES, AND DO HEREBY BIND MYSELF, MY SUCCESSORS AND ASSIGNS TO WARRANT AND FOREVER DEFEND THE TITLE TO THE LAND SO DEDICATED.

THIS IS TO CERTIFY THAT I, ROGER L. GALATAS, PRESIDENT OF THE WOODLANDS CORPORATION, OWNER OF THE PROPERTY SUBDIVIDED IN THE ABOVE AND FOREGOING MAP OF THE WOODLANDS VILLAGE OF ALDEN BRIDGE SECTION 38, HAVE COMPLIED OR WILL COMPLY WITH ALL REGULATIONS HERETOFORE ON FILE WITH THE MONTGOMERY COUNTY ENGINEER AND ADOPTED BY THE COMMISSIONERS' COURT OF MONTGOMERY COUNTY, TEXAS.

FURTHER, OWNER HAS DEDICATED AND BY THESE PRESENTS DOES DEDICATE TO THE USE OF THE PUBLIC FOR PUBLIC UTILITY PURPOSES FOREVER UNOBSTRUCTED AERIAL EASEMENTS. THE AERIAL EASEMENTS SHALL EXTEND HORIZONTALLY AN ADDITIONAL ELEVEN FEET, SIX INCHES (11' 6") FOR TEN FEET (10' 0") PERIMETER GROUND EASEMENTS OR FIVE FEET SIX INCHES (5' 6") FOR SIXTEEN FEET (16' 0") PERIMETER GROUND EASEMENTS, FROM A PLANE SIXTEEN FEET (16' 0") ABOVE GROUND LEVEL UPWARD, LOCATED ADJACENT TO AND ADJOINING SAID PUBLIC UTILITY EASEMENTS THAT ARE DESIGNATED WITH AERIAL EASEMENTS (U.E. & A.E.) AS INDICATED AND DEPICTED HEREON, WHEREBY THE AERIAL EASEMENT TOTALS TWENTY ONE FEET, SIX INCHES (21' 6") IN WIDTH.

FURTHER, OWNER HAS DEDICATED AND BY THESE PRESENTS DOES DEDICATE TO THE PUBLIC FOR PUBLIC UTILITY PURPOSES FOREVER UNOBSTRUCTED AERIAL EASEMENTS. THE AERIAL EASEMENTS SHALL EXTEND HORIZONTALLY AN ADDITIONAL TEN FEET (10' 0") FOR TEN FEET (10' 0") BACK-TO-BACK GROUND EASEMENTS OR SEVEN FEET (7' 0") FOR SIXTEEN FEET (16' 0") BACK-TO-BACK GROUND EASEMENTS, FROM A PLANE SIXTEEN FEET (16' 0") ABOVE GROUND LEVEL UPWARD, LOCATED ADJACENT TO BOTH SIDES AND ADJOINING SAID PUBLIC UTILITY EASEMENTS THAT ARE DESIGNATED WITH AERIAL EASEMENTS (U.E. & A.E.) AS INDICATED AND DEPICTED HEREON, WHEREBY THE AERIAL EASEMENT TOTALS THIRTY FEET (30' 0") IN WIDTH.

FURTHER, OWNER DOES HEREBY DEDICATE FOREVER TO THE PUBLIC A STRIP OF LAND A MINIMUM FIFTEEN (15' - 0") FEET WIDE ON EACH SIDE OF THE CENTERLINE OF ANY AND OF ALL GULLIES, RAVINES, DRAWS, SLOUGHS, OR OTHER NATURAL DRAINAGE COURSES LOCATED IN THE SAID SUBDIVISION, AS EASEMENTS FOR DRAINAGE PURPOSES, GIVING MONTGOMERY COUNTY AND/OR ANY OTHER PUBLIC AGENCY THE RIGHT TO ENTER UPON SAID EASEMENTS AT ANY AND ALL TIMES FOR THE PURPOSE OF CONSTRUCTING AND/OR MAINTAINING DRAINAGE WORK AND/OR STRUCTURES.

FURTHER, ALL OF THE PROPERTY SUBDIVIDED IN THE ABOVE AND FOREGOING MAP SHALL BE RESTRICTED IN ITS USE, WHICH RESTRICTIONS SHALL RUN WITH THE TITLE TO THE PROPERTY, AND SHALL BE ENFORCEABLE, AT THE OPTION OF MONTGOMERY COUNTY, BY MONTGOMERY COUNTY OR ANY CITIZEN THEREOF, BY INJUNCTION, AS FOLLOWS:

1. THAT DRAINAGE OF SEPTIC TANKS INTO ROAD, STREET, ALLEY, OR OTHER PUBLIC DITCHES, EITHER DIRECTLY OR INDIRECTLY, IS STRICTLY PROHIBITED.
2. DRAINAGE STRUCTURES UNDER PRIVATE DRIVEWAYS SHALL HAVE A NET DRAINAGE OPENING AREA OF SUFFICIENT SIZE TO PERMIT THE FREE FLOW OF WATER WITHOUT BACKWATER, AND SHALL BE A MINIMUM OF ONE AND THREE QUARTERS (1-3/4) SQUARE FEET (18" DIAMETER PIPE CULVERT).

FURTHER, OWNER DOES HEREBY DECLARE THAT ALL PARCELS OF LAND DESIGNATED AS LOTS ON THIS PLAT ARE ORIGINALLY INTENDED FOR THE CONSTRUCTION OF RESIDENTIAL DWELLING UNITS THEREON AND SHALL BE RESTRICTED FOR SAME UNDER THE TERMS AND CONDITIONS OF SUCH RESTRICTIONS FILED SEPARATELY, UNLESS OTHERWISE NOTED.

FURTHER, OWNER DOES HEREBY CERTIFY THAT IT IS THE OWNER OF ALL PROPERTY IMMEDIATELY ADJACENT TO THE BOUNDARIES OF THE ABOVE AND FOREGOING PLAT OF THE WOODLANDS VILLAGE OF ALDEN BRIDGE SECTION 38 WHERE BUILDING SETBACK LINES OR PUBLIC UTILITY EASEMENTS ARE TO BE ESTABLISHED OUTSIDE THE BOUNDARIES OF THE ABOVE AND FOREGOING PLAT AND DOES HEREBY MAKE AND ESTABLISH ALL BUILDING SETBACK LINES AND DEDICATES TO THE USE OF THE PUBLIC FOREVER ALL PUBLIC UTILITY EASEMENTS SHOWN IN SAID ADJACENT ACREAGE.

IN TESTIMONY WHEREOF, THE WOODLANDS CORPORATION HAS CAUSED THESE PRESENTS TO BE SIGNED BY ROGER L. GALATAS, ITS PRESIDENT, THEREUNTO AUTHORIZED, THIS 3rd DAY OF January, 1997.

THE WOODLANDS CORPORATION
Roger L. Galatas
ROGER L. GALATAS,
PRESIDENT

STATE OF TEXAS
COUNTY OF MONTGOMERY

BEFORE ME, THE UNDERSIGNED AUTHORITY, ON THIS DAY PERSONALLY APPEARED ROGER L. GALATAS, PRESIDENT OF THE WOODLANDS CORPORATION, KNOWN TO ME TO BE THE PERSON WHOSE NAME IS SUBSCRIBED TO THE FOREGOING INSTRUMENT, AND ACKNOWLEDGED TO ME THAT HE EXECUTED THE SAME FOR THE PURPOSES AND CONSIDERATIONS THEREIN EXPRESSED, AND IN THE CAPACITY THEREIN AND HEREIN SET OUT, AND AS THE ACT AND DEED OF SAID CORPORATION.

GIVEN UNDER MY HAND AND SEAL OF OFFICE, THIS 3rd DAY OF January, 1997.

KATHY L. LEIBOLD
Notary Public, State of Texas
My Commission Expires
SEPTEMBER 19, 2000

Kathy L. Leibold
NOTARY PUBLIC IN AND FOR THE STATE OF TEXAS
MY COMMISSION EXPIRES 9-19-2000

I, JOHN G. DAVIDSON, AM REGISTERED UNDER THE LAWS OF THE STATE OF TEXAS TO PRACTICE THE PROFESSION OF SURVEYING AND HEREBY CERTIFY THAT THE ABOVE SUBDIVISION IS TRUE AND CORRECT, WAS PREPARED FROM AN ACTUAL SURVEY OF THE PROPERTY MADE UNDER MY SUPERVISION ON THE GROUND, THAT THE ELEVATION BENCHMARK REFLECTED ON THE FACE OF THE PLAT WAS ESTABLISHED AS REQUIRED BY REGULATION, THAT ALL CORNERS AND ANGLE POINTS OF THE BOUNDARIES OF THE ORIGINAL TRACT TO BE SUBDIVIDED OF REFERENCE HAVE BEEN MARKED WITH IRON RODS HAVING A DIAMETER OF NOT LESS THAN FIVE-EIGHTHS OF AN INCH (5/8") AND A LENGTH OF NOT LESS THAN THREE FEET (3'), AND THAT THE PLAT BOUNDARY CORNERS HAVE BEEN TIED TO THE NEAREST SURVEY CORNER.



John G. Davidson
PRINT NAME: JOHN G. DAVIDSON
TEXAS REGISTRATION: 1792

THIS IS TO CERTIFY THAT THE HOUSTON PLANNING COMMISSION OF THE CITY OF HOUSTON, TEXAS HAS APPROVED THIS PLAT AND SUBDIVISION OF THE WOODLANDS VILLAGE OF ALDEN BRIDGE SECTION 38 IN CONFORMANCE WITH THE LAWS OF THE STATE OF TEXAS AND THE ORDINANCES OF THE CITY OF HOUSTON AS SHOWN HEREON AND AUTHORIZED THE RECORDING OF THIS PLAT, THIS 10 DAY OF March, 1997.



By: *M. Marv Katz* M. MARVIN KATZ, CHAIRMAN
Attest: *Robert M. Litke* ROBERT M. LITKE, SECRETARY

I, J.D. BLANTON, COUNTY ENGINEER OF MONTGOMERY COUNTY, TEXAS, DO HEREBY CERTIFY THAT THE PLAT OF THIS SUBDIVISION COMPLIES WITH ALL OF THE EXISTING RULES AND REGULATIONS OF THIS OFFICE AS ADOPTED BY THE MONTGOMERY COUNTY COMMISSIONERS' COURT.

I FURTHER CERTIFY THAT THE PLAT OF THIS SUBDIVISION COMPLIES WITH REQUIREMENTS FOR INTERNAL SUBDIVISION DRAINAGE AS ADOPTED BY THE MONTGOMERY COUNTY COMMISSIONERS' COURT, HOWEVER, NO CERTIFICATION IS HEREBY GIVEN AS TO THE EFFECT OF DRAINAGE FROM THIS SUBDIVISION TO THE INTERCEPTING DRAINAGE ARTERY OR PARENT STREAM OR ANY OTHER AREA OF SUBDIVISION WITHIN THE WATERSHED.

J.D. Blanton
J.D. BLANTON
MONTGOMERY COUNTY ENGINEER

APPROVED BY THE COMMISSIONERS' COURT OF MONTGOMERY COUNTY, TEXAS, THIS 24 DAY OF March, 1997.

Mike Meador MIKE MEADOR, COMMISSIONER, PRECINCT 1
Malcolm Purvis MALCOLM PURVIS, COMMISSIONER, PRECINCT 2

ALAN B. SADLER
COUNTY JUDGE

Ed Chance ED CHANCE, COMMISSIONER, PRECINCT 3
Jim Simmons JIM SIMMONS, COMMISSIONER, PRECINCT 4

THE STATE OF TEXAS
COUNTY OF MONTGOMERY

I, MARK TURNBULL, CLERK OF THE COUNTY COURT OF MONTGOMERY COUNTY, TEXAS, DO HEREBY CERTIFY THAT THE WITHIN INSTRUMENT WITH ITS CERTIFICATE OF AUTHENTICATION WAS FILED FOR REGISTRATION IN MY OFFICE ON March 24, 1997 AT 9:30 O' CLOCK

A.M. AND DULY RECORDED ON April 1, 1997 AT 1:06 O' CLOCK P.M., IN CABINET I, SHEET 193-196, OF RECORD OF Maps FOR SAID COUNTY.

WITNESS MY HAND AND SEAL OF OFFICE, AT CONROE, MONTGOMERY COUNTY, TEXAS, THE DAY AND DATE LAST ABOVE WRITTEN.



Mark Turnbull
MARK TURNBULL, CLERK, COUNTY COURT
MONTGOMERY COUNTY, TEXAS

By: _____

FILED FOR RECORD
97 APR -1 PH 1:06

MARK TURNBULL, CO. CLERK
MONTGOMERY COUNTY, TEXAS

SS DEPUTY

THE WOODLANDS
VILLAGE OF
ALDEN BRIDGE
SECTION 38
SHEET 2 OF 4

File # 9718445 Cab. I Sheet 194



100 50 0 100 200
SCALE: 1" = 100'

THE WOODLANDS VILLAGE OF
ALDEN BRIDGE SECTION 34
CAB. "I" SHT. 133 - 136
M.C.M.R.

RESTRICTED RESERVE 'B'
(R.O.S.R.) 0.11 AC. 4,698 SQ. FT.
RESTRICTED FOR OPEN SPACE

THE WOODLANDS VILLAGE OF
ALDEN BRIDGE SECTION 37

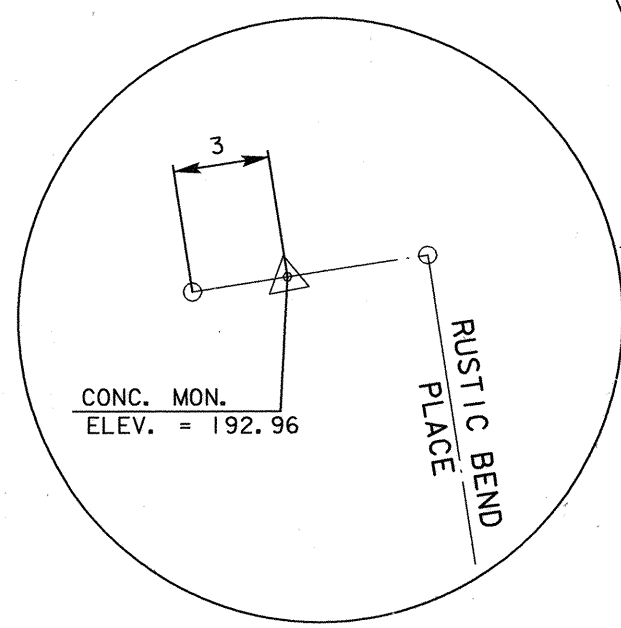

INSET

ACREAGE

RESTRICTED RESERVE 'A'
(R.O.S.R.) 1.29AC. 56,226 SQ. FT.
RESTRICTED FOR OPEN SPACE

EXIST. ALDEN BRIDGE DRIVE CAB. "I" SHT. 84 - 87 M.C.M.R.

ACREAGE

P. O. B.

A. SMITH A-499
WILLIAM H. HARRISON A-257

P. O. C.
X = 3095741.2270
Y = 874415.1850

MONTGOMERY COUNTY
SCHOOL LAND
ABSTRACT NO. 666

A. SMITH A-499

THE WOODLANDS
VILLAGE OF
ALDEN BRIDGE
SECTION 38
SHEET 3 OF 4

File# 9718445

Cab. I Sheet 195

GENERAL NOTES

1. D. E. INDICATES DRAINAGE EASEMENT. DRAINAGE EASEMENT SHALL HEREBY BE RESTRICTED TO KEEP CLEAR OF FENCES, BUILDING, PLANTING AND OTHER OBSTRUCTIONS TO THE OPERATIONS AND MAINTENANCE OF THE DRAINAGE FACILITY.
2. B. L. INDICATES BUILDING LINES.
3. S. S. E. INDICATES SANITARY SEWER EASEMENT.
4. STM. S. E. INDICATES STORM SEWER EASEMENT. MAINTAIN DRAINAGE BENEATH FENCES (MIN. 5' SQ. FT.) AND AROUND OTHER OBSTRUCTIONS THAT WOULD OTHERWISE INTERRUPT THE OPERATIONS AND MAINTENANCE OF THE DRAINAGE FACILITY.
5. 10' D. E. INDICATES DRAINAGE EASEMENT FOR SIDE LOTS. MAINTAIN DRAINAGE BENEATH FENCES (MIN. 5' SQ. FT.) AND AROUND OTHER OBSTRUCTIONS THAT WOULD OTHERWISE INTERRUPT THE OPERATIONS AND MAINTENANCE OF THE DRAINAGE FACILITY.
6. W. L. E. INDICATES WATER LINE EASEMENT.
7. U. E. INDICATES UTILITY EASEMENT.
8. ALL UTILITY EASEMENTS EXTEND EQUAL DISTANCE EITHER SIDE OF PROPERTY LINES UNLESS OTHERWISE NOTED.
9. 1' ONE-FOOT RESERVE DEDICATED TO THE PUBLIC IN FEE AS A BUFFER SEPARATION BETWEEN THE SIDE OR END OF STREETS WHERE SUCH STREETS ABUT ADJACENT ACREAGE TRACTS. THE CONDITION OF SUCH DEDICATION BEING THAT WHEN THE ADJACENT PROPERTY IS SUBDIVIDED IN A RECORDED PLAT, THE ONE-FOOT RESERVE SHALL THEREUPON BECOME VESTED IN THE PUBLIC FOR STREET RIGHT-OF-WAY PURPOSES AND THE FEE TITLE THERETO SHALL REVERT TO AND REVEST IN THE DEDICATOR, HIS HEIRS, ASSIGNS OR SUCCESSORS.
10. THIS SURVEY IS NOT TIED INTO THE OFFICIAL CITY OF HOUSTON SURVEY SYSTEM IN COMPLIANCE WITH ORDINANCE NO. 69-1978, BECAUSE A CITY OF HOUSTON SURVEY MARKER HAS NOT BEEN ESTABLISHED WITHIN 2,000 FEET OF THIS PROPERTY.
11. ALL BEARINGS REFERENCED TO THE TEXAS STATE PLANE COORDINATE SYSTEM SOUTH CENTRAL ZONE.
12. LOTS ADJACENT TO RESTRICTED OPEN SPACE RESERVES ARE DENIED DIRECT DRIVEWAY ACCESS ACROSS SAID RESERVES.
13. R. O. S. R. INDICATES OPEN SPACE RESERVE.

CURVE TABLE

CURVE	RADIUS	TANGENT	CHORD	ARC	DELTA	CHORD BEARING
1	780.00	21.31	42.60	42.60	03°07'47"	S-06-02-26-E
2	780.00	54.88	109.48	109.57	08°02'58"	S-00-27-05-E
3	25.00	25.00	35.36	39.27	90°00'00"	S-41-26-37-E
4	25.00	25.00	35.36	39.27	90°00'01"	N-41-26-37-W
5	835.00	146.50	288.59	290.05	19°54'09"	N-06-22-41-W
6	3035.00	175.98	351.37	351.57	06°38'13"	N-19-38-52-W
7	25.00	25.00	35.36	39.27	90°00'00"	N-48-34-24-E
8	25.00	25.00	35.36	39.27	98°02'56"	N-45-27-05-W
9	25.00	25.00	35.36	39.27	90°00'00"	N-40-31-28-E
10	720.00	50.88	101.51	101.60	08°05'05"	N-08-31-05-W
11	530.00	27.43	54.78	54.80	05°56'28"	I-09-35-54-W
12	280.00	193.58	318.46	338.74	69°18'57"	N-41-17-38-W
13	270.00	264.33	325.87	349.83	74°14'09"	S-67-14-29-W
14	270.00	1' 4.45	210.75	216.51	45°56'39"	S-07-09-05-W
15	170.00	120.38	196.49	209.49	70°38'20"	S-51-07-23-E
16	720.00	7.80	15.60	15.60	01°14'29"	S-87-02-52-E
17	25.00	25.00	35.36	39.27	90°00'00"	N-45-15-37-L
18	725.00	79.16	157.38	157.69	12°27'44"	N-08-02-31-W
19	775.00	36.85	73.62	73.65	05°26'41"	N-11-33-03-W
20	114.00	37.75	71.77	72.90	36°38'28"	N-27-08-56-W
21	50.00	*	85.00	212.42	243° 1' 59"	N-76-14-20-E
22	114.00	27.11	52.75	53.24	26°44'23"	S-04-34-08-W
23	725.00	34.59	69.11	69.14	05°27'49"	S-11-32-28-E
24	775.00	84.74	168.48	163.81	12°28'49"	S-08-01-59-E
25	25.00	26.20	36.17	40.44	92°40'58"	S-48-08-03-E
26	780.00	54.88	109.48	109.57	08°02'55"	S-89-32-56-W
27	230.00	46.91	91.93	92.56	23°03'26"	N-74-53-54-W
28	25.00	16.33	27.34	28.93	66°18'20"	S-83-28-39-W
29	50.00	424.95	99.31	145.37	166°34'44"	N-46-23-09-W
30	25.00	16.33	27.34	28.93	66°18'20"	N-03-48-03-E
31	230.00	27.39	54.39	54.52	13°34'53"	N-22-36-41-W
32	330.00	65.74	128.95	129.79	22°32'03"	N-04-33-13-W
33	25.00	20.17	31.40	33.95	77°48'12"	N-32-11-17-W
34	50.00	*	100.00	157.08	180°00'00"	N-18-54-37-E
35	25.00	20.53	31.73	34.38	78°47'13"	N-69-31-00-E
36	330.00	249.62	398.16	427.42	74°12'37"	N-67-13-43-E
37	340.00	234.93	386.55	411.15	69°17'08"	S-41-16-44-E
38	470.00	24.32	48.58	48.60	05°56'28"	S-09-36-54-E
39	780.00	33.75	67.44	67.46	04°57'19"	S-10-04-58-E
40	230.00	7.89	15.78	15.78	03°58'51"	N-84-27-42-W
41	230.00	28.43	56.43	56.57	14°05'31"	N-70-24-57-W
42	170.00	116.03	191.68	203.63	88°37'59"	N-50-08-08-W
43	280.00	77.85	150.00	151.86	31°04'32"	S-60-24-51-E
44	280.00	85.99	164.41	166.87	34°08'44"	S-23-42-32-E
45	50.00	30.52	52.11	54.81	62°48'24"	N-13-27-23-W
46	50.00	242.19	97.93	136.72	156°40'14"	S-32-51-57-W
47	170.00	2.93	5.86	5.86	01°58'30"	N-85-26-13-W
48	230.00	10.11	20.20	20.21	05°02'04"	S-79-58-44-E
49	50.00	10.87	20.74	20.69	23°58'21"	N-56-49-46-W
50	280.00	10.01	20.01	20.01	04°05'40"	S-42-49-44-E
51	750.00	52.77	105.27	105.36	08°02'55"	N-00-27-05-W
52	750.00	53.00	105.74	105.83	08°05'05"	N-08-31-05-W
53	500.00	25.87	51.68	51.70	05°56'28"	N-09-36-54-W
54	310.00	214.20	352.44	374.87	69°17'08"	N-41-16-44-W
55	300.00	227.04	362.07	388.70	74°14'09"	S-67-14-29-W
56	300.00	127.17	234.17	240.56	45°56'39"	S-07-09-05-W
57	200.00	141.62	231.18	245.46	70°38'22"	S-51-07-26-E
58	750.00	52.77	105.27	105.36	08°02'55"	N-89-32-56-E
59	750.00	35.79	71.49	71.52	05°27'49"	S-11-32-28-E
60	750.00	82.00	163.03	163.35	12°28'45"	S-08-02-01-E

LINE TABLE

LINE	BEARING	DISTANCE
1	S-83-27-21-E	158.72
2	S-72-48-54-E	102.33
3	S-49-54-09-E	216.38
4	S-20-55-22-E	134.69
5	S-12-05-40-E	70.32
6	S-07-04-08-E	202.78
7	S-18-59-56-E	97.32
8	S-04-28-32-E	57.74
9	S-85-31-28-W	122.35
10	S-04-28-32-E	135.92
11	S-03-34-23-W	55.47
12	N-03-34-23-E	37.30
13	N-16-19-45-W	80.53
14	N-22-57-59-W	30.14
15	N-86-25-37-W	130.00
16	N-03-34-23-E	129.21
17	N-10-44-38-E	62.18
18	N-04-28-32-W	47.42
19	N-12-33-38-W	61.69
20	N-06-38-10-W	146.29
21	S-30-07-24-W	17.51
22	S-15-49-15-E	220.69
23	S-86-25-37-W	64.45
24	N-14-16-23-W	61.16
25	S-08-48-34-E	23.79
26	S-14-16-23-E	61.16
27	N-85-31-28-E	185.50
28	S-85-31-28-W	186.58
29	N-86-25-37-W	64.45
30	N-15-49-15-W	220.69
31	N-71-05-24-W	8.00
32	S-71-05-21-E	7.95
33	N-30-07-24-E	11.42
34	S-08-38-09-E	146.29
35	S-12-33-38-E	61.69
36	N-86-25-37-W	20.92
37	S-85-31-28-W	16.33
38	N-86-25-37-W	10.00
39	N-41-25-37-W	10.00
40	N-02-45-24-W	15.16
41	N-15-49-15-W	18.77
42	N-23-06-16-W	26.16
43	N-39-58-32-E	6.55
44	N-73-23-54-E	23.36
45	S-83-27-21-E	13.17
46	S-72-48-54-E	29.16
47	S-20-55-22-E	18.04
48	S-20-55-22-E	29.18
49	S-12-05-40-E	13.68
50	S-18-59-56-E	26.87
51	S-85-31-28-W	171.68
52	S-18-08-39-W	119.38
53	S-17-57-21-E	66.24
54	S-41-25-37-E	64.31
55	N-17-52-06-W	12.55
56	N-15-49-15-W	24.58
57	S-06-38-10-E	23.85
58	S-05-44-02-F	1.46
59	S-11-49-38-E	7.68
60	N-58-52-08-W	60.68
61	N-80-23-53-W	63.50
62	S-78-18-09-W	53.29
63	S-52-57-50-W	63.16
64	S-33-14-24-W	64.41
65	S-11-18-00-W	63.26
66	S-11-11-28-E	65.82
67	S-22-18-04-E	57.83
68	S-11-07-09-E	72.03
69	S-05-54-02-E	76.30
70	S-85-31-28-W	37.54
71	N-14-16-23-W	1.58
72	N-08-48-34-W	8.02
73	N-08-48-34-W	15.77
74	N-11-05-06-W	61.11
75	N-30-48-04-W	56.58
76	S-33-14-24-W	11.41
77	S-11-07-09-E	2.64
78	N-85-31-28-E	15.00
79	N-67-02-01-E	30.00
80	N-04-28-32-W	64.50
81	S-86-25-37-E	64.45
82	N-43-36-51-E	35.11
83	S-71-05-23-E	54.99
84	N-81-11-25-E	7.44
85	S-08-48-34-E	97.62
86	S-01-47-38-E	56.59

RESERVES

RESERVE	ACREAGE	SQ. FT.	TYPE
A	1.29	56,226	RESTRICTED FOR OPEN SPACE USE ONLY
B	0.11	4,698	RESTRICTED FOR OPEN SPACE USE ONLY
TOTAL	1.40	60,924	-----