

THE WOODLANDS GROGAN'S FOREST SECTION 9

BEING 15.725 ACRES OUT OF THE
JAMES STEPHENS SURVEY, ABSTRACT 536
MONTGOMERY COUNTY, TEXAS

OWNER: THE WOODLANDS LAND DEVELOPMENT COMPANY, L.P.
2201 TIMBERLOCH PLACE
THE WOODLANDS, TEXAS 77380

2 BLOCKS 40 LOTS
5 RESERVES
4.909 ACRES IN RESERVE

ENGINEER: **LJA Engineering & Surveying, Inc.**
2929 Briarpark Drive
Suite 600
Houston, Texas 77042-3703
Phone 713.953.5200
Fax 713.953.5026

DATE: OCTOBER 19, 2004

SHEET 1 OF 3

File 2004 127781 CAB X Sheet 28

I:\Projects\2004\127781\127781.dwg
11-03-2004 16:59:09

2004 NOV 16 PM 4:08

STATE OF TEXAS
COUNTY OF MONTGOMERY

THE WOODLANDS LAND DEVELOPMENT COMPANY, L.P., ACTING HEREIN BY AND THROUGH THE WOODLANDS OPERATING COMPANY, L.P., ITS AUTHORIZED AGENT, ACTING HEREIN BY AND THROUGH ITS PRESIDENT AND CEO, THOMAS J. D'ALESSANDRO, IV, OWNER (HEREINAFTER REFERRED TO AS OWNER) OF THE PROPERTY SUBDIVIDED IN THE ABOVE AND FOREGOING MAP OF THE WOODLANDS, GROGAN'S FOREST, SEC. 9, DO HEREBY MAKE SUBDIVISION OF SAID PROPERTY FOR AND ON BEHALF OF SAID THE WOODLANDS LAND DEVELOPMENT COMPANY, L.P., ACCORDING TO THE LINES, STREETS, LOTS, ALLEYS, PARKS, BUILDING LINES AND EASEMENTS THEREON SHOWN AND DESIGNATE SAID SUBDIVISION AS THE WOODLANDS, GROGAN'S FOREST, SEC. 9, LOCATED IN THE JAMES STEPHENS SURVEY, ABSTRACT 536, MONTGOMERY COUNTY, TEXAS AND ON BEHALF OF SAID THE WOODLANDS LAND DEVELOPMENT COMPANY, L.P. AND DEDICATE TO PUBLIC USE, AS SUCH, THE STREETS (EXCEPT THOSE STREETS DESIGNATED AS PRIVATE STREETS OR PERMANENT ACCESS EASEMENTS), ALLEYS, PARKS AND EASEMENTS SHOWN THEREON FOREVER, AND DO HEREBY WAIVE ANY CLAIMS FOR DAMAGES OCCASIONED BY THE ESTABLISHING OF GRADES AS APPROVED FOR THE STREETS AND ALLEYS DEDICATED, OR OCCASIONED BY THE ALTERATION OF THE SURFACE OF ANY PORTION OF STREETS OR ALLEYS TO CONFORM TO SUCH GRADES, AND DO HEREBY BIND OURSELVES, OUR SUCCESSORS AND ASSIGNS TO WARRANT AND FOREVER DEFEND THE TITLE TO THE LAND SO DEDICATED.

THIS IS TO CERTIFY THAT THE WOODLANDS LAND DEVELOPMENT COMPANY, L.P. ACTING HEREIN BY AND THROUGH THE WOODLANDS OPERATING COMPANY, L.P., ITS AUTHORIZED AGENT, ACTING HEREIN BY AND THROUGH ITS PRESIDENT AND CEO, THOMAS J. D'ALESSANDRO, IV, OWNER OF THE PROPERTY SUBDIVIDED IN THE ABOVE AND FOREGOING MAP OF THE WOODLANDS, GROGAN'S FOREST, SEC. 9, HAVE COMPLIED OR WILL COMPLY WITH ALL REGULATIONS HERETOFORE ON FILE WITH THE MONTGOMERY COUNTY ENGINEER AND ADOPTED BY THE COMMISSIONERS COURT OF MONTGOMERY COUNTY, TEXAS.

FURTHER, OWNER HAS DEDICATED AND BY THESE PRESENTS DOES DEDICATE TO THE USE OF THE PUBLIC FOR PUBLIC UTILITY PURPOSES FOREVER UNOBSTRUCTED AERIAL EASEMENTS, THE AERIAL EASEMENTS SHALL EXTEND HORIZONTALLY AN ADDITIONAL ELEVEN FEET SIX INCHES (11' 6") FOR TEN FEET (10' 0") PERIMETER GROUND EASEMENTS OR FIVE FEET SIX INCHES (5' 6") FOR SIXTEEN FEET (16' 0") PERIMETER GROUND EASEMENTS FROM A PLANE SIXTEEN FEET (16' 0") ABOVE GROUND LEVEL UPWARD, LOCATED ADJACENT TO AND ADJOINING SAID PUBLIC UTILITY EASEMENTS THAT ARE DESIGNATED WITH AERIAL EASEMENTS (U.E. & A.E.) AS INDICATED AND DEPICTED HEREON, WHEREBY, THE AERIAL EASEMENT TOTALS TWENTY-ONE FEET, SIX INCHES (21' 6") IN WIDTH.

FURTHER, OWNER HAS DEDICATED AND BY THESE PRESENTS DOES DEDICATE TO THE USE OF THE PUBLIC FOR PUBLIC UTILITY PURPOSES FOREVER UNOBSTRUCTED AERIAL EASEMENTS. THE AERIAL EASEMENTS SHALL EXTEND HORIZONTALLY AN ADDITIONAL TEN FEET (10' 0") FOR TEN FEET (10' 0") BACK-TO-BACK GROUND EASEMENTS OR SEVEN FEET (7' 0") FOR SIXTEEN FEET (16' 0") BACK-TO-BACK GROUND EASEMENTS, FROM A PLANE SIXTEEN FEET (16' 0") ABOVE GROUND LEVEL UPWARD, LOCATED ADJACENT TO BOTH SIDES AND ADJOINING SAID PUBLIC UTILITY EASEMENTS THAT ARE DESIGNATED WITH AERIAL EASEMENTS (U.E. & A.E.) AS INDICATED AND DEPICTED HEREON, WHEREBY, THE AERIAL EASEMENT TOTALS THIRTY FEET (30' 0") IN WIDTH.

FURTHER, OWNERS DO HEREBY DEDICATE FOREVER TO THE PUBLIC A STRIP OF LAND A MINIMUM FIFTEEN FEET (15' 0") WIDE ON EACH SIDE OF THE CENTERLINE OF ANY AND ALL GULLIES, RAVINES, DRAWS, SLOUGHS, OR OTHER NATURAL DRAINAGE COURSES LOCATED IN THE SAID SUBDIVISION, AS EASEMENTS FOR DRAINAGE PURPOSES, GIVING MONTGOMERY COUNTY AND/OR ANY OTHER PUBLIC AGENCY THE RIGHT TO ENTER UPON SAID EASEMENTS AT ANY AND ALL TIMES FOR THE PURPOSE OF CONSTRUCTING AND/OR MAINTAINING DRAINAGE WORK AND/OR STRUCTURES.

FURTHER, ALL OF THE PROPERTY SUBDIVIDED IN THE ABOVE AND FOREGOING MAP SHALL BE RESTRICTED IN ITS USE, WHICH RESTRICTIONS SHALL RUN WITH THE TITLE TO THE PROPERTY, AND SHALL BE ENFORCEABLE, AT THE OPTION OF MONTGOMERY COUNTY, BY MONTGOMERY COUNTY OR ANY CITIZEN THEREOF, BY INJUNCTION, AS FOLLOWS:

1. THAT DRAINAGE OF SEPTIC TANKS INTO ROAD, STREET, ALLEY, OR OTHER PUBLIC DITCHES, EITHER DIRECTLY OR INDIRECTLY IS STRICTLY PROHIBITED.
2. DRAINAGE STRUCTURES UNDER PRIVATE DRIVEWAYS SHALL HAVE A NET DRAINAGE OPENING AREA OF SUFFICIENT SIZE TO PERMIT THE FREE FLOW OF WATER WITHOUT BACKWATER, AND SHALL BE A MINIMUM OF ONE AND THREE QUARTERS (1-3/4) SQUARE FEET (18" DIAMETER PIPE CULVERT)

FURTHER, OWNERS DO HEREBY DECLARE THAT ALL PARCELS OF LAND DESIGNATED AS LOTS ON THIS PLAT ARE ORIGINALLY INTENDED FOR THE CONSTRUCTION OF SINGLE-FAMILY RESIDENTIAL DWELLING UNITS THEREON AND SHALL BE RESTRICTED FOR SAME UNDER THE TERMS AND CONDITIONS OF SUCH RESTRICTIONS FILED SEPARATELY, UNLESS OTHERWISE NOTED.

IN TESTIMONY WHEREOF, THE WOODLANDS OPERATING COMPANY, L.P., A TEXAS LIMITED PARTNERSHIP, ACTING IN ITS CAPACITY AS AUTHORIZED AGENT OF THE WOODLANDS LAND DEVELOPMENT COMPANY, L.P., A TEXAS LIMITED PARTNERSHIP, HAS CAUSED THESE PRESENTS TO BE SIGNED BY THOMAS J. D'ALESSANDRO, IV, ITS PRESIDENT AND CEO, THEREUNTO AUTHORIZED THIS THE 4 DAY OF OCTOBER 2004.

THE WOODLANDS LAND DEVELOPMENT COMPANY, L.P.
A TEXAS LIMITED PARTNERSHIP

BY: THE WOODLANDS OPERATING COMPANY, L.P.
A TEXAS LIMITED PARTNERSHIP
ITS AUTHORIZED AGENT

BY: Thomas J. D'Alessandro, IV
THOMAS J. D'ALESSANDRO, IV
PRESIDENT AND CEO

STATE OF TEXAS
COUNTY OF MONTGOMERY

BEFORE ME, THE UNDERSIGNED AUTHORITY, ON THIS DAY PERSONALLY APPEARED THOMAS J. D'ALESSANDRO, IV, PRESIDENT AND CEO OF THE WOODLANDS OPERATING COMPANY, L.P., A TEXAS LIMITED PARTNERSHIP, AUTHORIZED AGENT OF THE WOODLANDS LAND DEVELOPMENT COMPANY, L.P., A TEXAS LIMITED PARTNERSHIP, KNOWN TO ME TO BE THE PERSON WHOSE NAME IS SUBSCRIBED TO THE FOREGOING INSTRUMENT AND ACKNOWLEDGED TO ME THAT HE EXECUTED THE SAME FOR THE PURPOSES AND CONSIDERATIONS THEREIN EXPRESSED, AND IN THE CAPACITY THEREIN AND HEREIN SET OUT AND AS AN ACT AND DEED OF SAID LIMITED PARTNERSHIP.

GIVEN, UNDER MY HAND AND SEAL OF OFFICE, THIS 4 DAY OF October, 2004.

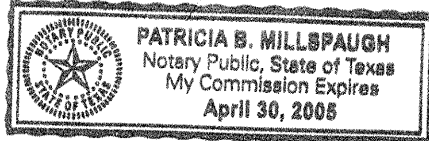

Patricia B. Millspaugh
NOTARY PUBLIC IN AND FOR THE STATE OF TEXAS

I, STEPHEN P. MATOVICH, AM REGISTERED UNDER THE LAWS OF THE STATE OF TEXAS TO PRACTICE THE PROFESSION OF SURVEYING AND HEREBY CERTIFY THAT THE ABOVE SUBDIVISION IS TRUE AND CORRECT, WAS PREPARED FROM AN ACTUAL SURVEY OF THE PROPERTY MADE UNDER MY SUPERVISION ON THE GROUND, THAT THE ELEVATION BENCHMARK REFLECTED ON THE FACE OF THE PLAT WAS ESTABLISHED AS REQUIRED BY REGULATION, THAT ALL CORNERS AND ANGLE POINTS OF THE BOUNDARIES OF THE ORIGINAL TRACT TO BE SUBDIVIDED OF REFERENCE HAVE BEEN MARKED WITH IRON RODS HAVING A DIAMETER OF NOT LESS THAN FIVE-EIGHTHS OF AN INCH (5/8") AND A LENGTH OF NOT LESS THAN THREE FEET (3'), AND THAT THE PLAT BOUNDARY CORNERS HAVE BEEN TIED TO THE NEAREST SURVEY CORNER.

Stephen P. Matovich 9-30-04
STEPHEN P. MATOVICH
TEXAS REGISTRATION NO. 5347



THIS IS TO CERTIFY THAT THE PLANNING COMMISSION OF THE CITY OF HOUSTON, TEXAS HAS APPROVED THIS PLAT AND SUBDIVISION OF THE WOODLANDS, GROGAN'S FOREST, SEC. 9 IN CONFORMANCE WITH THE LAWS OF THE STATE OF TEXAS AND THE ORDINANCES OF THE CITY OF HOUSTON AS SHOWN HEREON AND AUTHORIZED THE RECORDING OF THIS PLAT, THIS 22 DAY OF OCT 2004.

M. Marvin Katz
M. MARVIN KATZ, CHAIRMAN
Robert M. Litke
ROBERT M. LITKE
SECRETARY

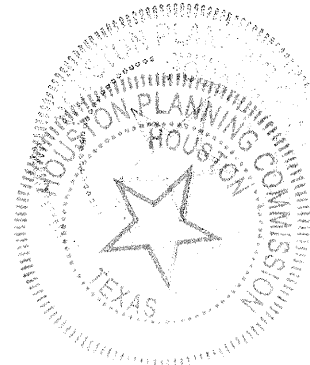

I, MARK J. MOONEY, P.E., COUNTY ENGINEER OF MONTGOMERY COUNTY, TEXAS, DO HEREBY CERTIFY THAT THE PLAT OF THIS SUBDIVISION COMPLIES WITH ALL OF THE EXISTING RULES AND REGULATIONS OF THIS OFFICE AS ADOPTED BY THE MONTGOMERY COUNTY COMMISSIONERS' COURT.

I FURTHER CERTIFY THAT THE PLAT OF THIS SUBDIVISION COMPLIES WITH REQUIREMENTS FOR INTERNAL SUBDIVISION DRAINAGE AS ADOPTED BY THE MONTGOMERY COUNTY COMMISSIONERS' COURT; HOWEVER, NO CERTIFICATION IS HEREBY GIVEN AS TO THE EFFECT OF DRAINAGE FROM THIS SUBDIVISION TO THE INTERCEPTING DRAINAGE ARTERY OR PARENT STREAM OR ANY OTHER AREA OF SUBDIVISION WITHIN THE WATERSHED.

Mark J. Mooney
MARK J. MOONEY, P.E.
MONTGOMERY COUNTY ENGINEER



APPROVED BY THE COMMISSIONERS' COURT OF MONTGOMERY COUNTY, TEXAS, THIS 15 DAY OF NOV, 2004.

Mike Meador
MIKE MEADOR
COMMISSIONER, PRECINCT 1
Craig Doyal
CRAIG DOYAL
COMMISSIONER, PRECINCT 2
Alan B. Sadler
ALAN B. SADLER
COUNTY JUDGE
Ed Chance
ED CHANCE
COMMISSIONER, PRECINCT 3
Ed Rinehart
ED RINEHART
COMMISSIONER, PRECINCT 4

GENERAL NOTES

1. UNLESS OTHERWISE INDICATED, THE BUILDING LINES (B.L.), WHETHER ONE OR MORE, SHOWN ON THIS PLAT ARE ESTABLISHED TO EVIDENCE COMPLIANCE WITH THE APPLICABLE PROVISIONS OF CHAPTER 42, CODE OF ORDINANCES, CITY OF HOUSTON, TEXAS, IN EFFECT AT THE TIME THIS PLAT WAS APPROVED, WHICH MAY BE AMENDED FROM TIME TO TIME.
2. SINGLE FAMILY RESIDENTIAL SHALL MEAN THE USE OF A LOT WITH ONE BUILDING DESIGNED FOR AND CONTAINING NOT MORE THAN TWO SEPARATE UNITS WITH FACILITIES FOR LIVING, SLEEPING, COOKING AND EATING THEREIN. A LOT UPON WHICH IS LOCATED A FREE-STANDING BUILDING CONTAINING ONE DWELLING UNIT AND A DETACHED SECONDARY DWELLING UNIT OF NOT MORE THAN 900 SQUARE FEET ALSO SHALL BE CONSIDERED SINGLE FAMILY RESIDENTIAL. A BUILDING THAT CONTAINS ONE DWELLING UNIT ON ONE LOT THAT IS CONNECTED BY A PARTY WALL TO ANOTHER BUILDING CONTAINING ONE DWELLING UNIT ON AN ADJACENT LOT SHALL BE SINGLE FAMILY RESIDENTIAL.
3. EACH LOT SHALL PROVIDE A MINIMUM OF TWO OFF-STREET PARKING SPACES PER DWELLING UNIT ON EACH LOT. IN THOSE INSTANCES WHERE A SECONDARY UNIT IS PROVIDED ONLY ONE ADDITIONAL SPACE SHALL BE PROVIDED.
4. THE COORDINATES SHOWN HEREON ARE TEXAS CENTRAL ZONE NO. 4203 STATE PLANE GRID COORDINATES (NAD 83) AND MAY BE BROUGHT TO SURFACE BY APPLYING THE FOLLOWING COMBINED SCALE: 0.99998064
5. ALL BEARINGS ARE REFERENCED TO THE 1927 TEXAS STATE PLANE COORDINATE SYSTEM, LAMBERT PROJECTION, SOUTH CENTRAL ZONE.
6. ALL SPLIT UTILITY EASEMENTS EXTEND EQUAL DISTANCE EITHER SIDE OF PROPERTY LINES UNLESS OTHERWISE SHOWN.
7. LOTS ADJACENT TO RESTRICTED RESERVES RESTRICTED TO OPEN SPACE ARE DENIED DIRECT DRIVEWAY ACCESS ACROSS SAID RESERVES.
8. THE FOLLOWING RESTRICTIONS SHALL PERTAIN TO ANY DRAINAGE EASEMENT CONTAINED WITHIN THE BOUNDARIES OF THIS PLAT:
 - A. PROHIBITS ALL PROPERTIES ABUTTING THE EASEMENT FROM THE CONSTRUCTION OF FENCES OR BUILDINGS, WHETHER TEMPORARY OR PERMANENT, AND THE INSTALLATION OR MAINTENANCE OF PLANTING OR OTHER OBSTRUCTIONS TO THE OPERATION AND MAINTENANCE OF THE DRAINAGE FACILITY WITHIN THE DRAINAGE EASEMENT.
 - B. PROHIBITS ANY PROPERTY ABUTTING THE DRAINAGE EASEMENT FROM DRAINAGE DIRECTLY INTO THE DRAINAGE EASEMENT EXCEPT BY MEANS OF A DRAINAGE STRUCTURE APPROVED BY THE DIRECTOR OF PUBLIC WORKS AND ENGINEERING OR THE AUTHORIZED PUBLIC DRAINAGE OR FLOOD CONTROL OFFICIAL.
9. ONE-FOOT RESERVE DEDICATED TO THE PUBLIC IN FEE AS A BUFFER SEPARATION BETWEEN THE SIDE OR END OF STREETS WHERE SUCH STREETS ABUT ADJACENT PROPERTY, THE CONDITION OF THIS DEDICATION BEING THAT WHEN THE ADJACENT PROPERTY IS SUBDIVIDED OR RESUBDIVIDED IN A RECORDED SUBDIVISION PLAT, THE ONE-FOOT RESERVE SHALL THEREUPON BECOME VESTED IN THE PUBLIC FOR STREET-RIGHT-OF-WAY PURPOSES AND THE FEE TITLE THERETO SHALL REVERT TO AND REVEST IN THE DEDICATOR, HIS HEIRS, ASSIGNS OR SUCCESSORS.

THE STATE OF TEXAS
COUNTY OF MONTGOMERY

I, MARK TURNBULL, CLERK OF THE COUNTY COURT OF MONTGOMERY COUNTY, TEXAS, DO HEREBY CERTIFY THAT THE WITHIN INSTRUMENT WITH ITS CERTIFICATE OF AUTHENTICATION WAS FILED

FOR REGISTRATION IN MY OFFICE ON 11-15-04 AT 9:30 O'CLOCK A.M., AND DULY RECORDED ON 11-16, 2004 AT 4:08 O'CLOCK P.M., IN CABINET X, SHEET 28-30, OF

RECORD OF _____ FOR SAID COUNTY.

WITNESS MY HAND AND SEAL OF OFFICE, AT CONROE, MONTGOMERY COUNTY, TEXAS THE DAY AND DATE LAST ABOVE WRITTEN.

Mark Turnbull
MARK TURNBULL, CLERK OF THE COUNTY COURT
MONTGOMERY COUNTY, TEXAS
BY: Jenni Menech
DEPUTY

OWNER: THE WOODLANDS LAND DEVELOPMENT COMPANY, L.P.
2201 TIMBERLOCH PLACE
THE WOODLANDS, TEXAS 77380

THE WOODLANDS
GROGAN'S FOREST
SECTION 9
SHEET 2 OF 3

File 2004 127781

CAB X

sheet 29

CURVE	RADIUS	TANGENT	CHORD	ARC	DELTA	CHORD BEARING
1	1200.00	20.37	40.74	40.74	01°56'43"	S-32-56-07-W
2	25.00	23.71	34.40	37.94	86°57'30"	S-75-26-30-W
3	2040.00	9.99	19.99	19.99	00°33'41"	N-61-21-35-W
4	300.00	23.84	45.55	45.55	08°42'28"	N-59-59-39-W
5	175.00	32.91	64.68	65.06	21°18'00"	N-53-44-10-W
6	175.00	78.92	143.89	148.28	48°32'53"	N-40-06-44-W
7	25.00	24.25	34.81	38.51	88°15'31"	N-59-58-01-W
8	105.00	105.00	148.49	164.93	90°00'00"	N-59-05-46-W
9	55.00	55.00	77.78	86.39	90°00'00"	S-59-05-46-E
10	55.00	55.00	77.78	86.39	90°00'00"	N-30-54-14-E
11	55.00	55.00	77.78	86.39	90°00'00"	N-59-05-46-W
12	55.00	55.00	77.78	86.39	90°00'00"	S-30-54-14-W
13	105.00	21.22	41.60	41.88	22°51'09"	N-02-40-12-W
14	25.00	21.25	32.38	35.22	80°43'42"	N-31-36-29-W
15	275.00	49.52	97.47	97.98	20°24'54"	N-82-10-46-W
16	60.00	67.26	89.55	101.08	96°31'42"	S-39-20-56-W
17	325.00	27.19	54.19	54.25	09°33'51"	S-13-41-50-E
18	100.00	30.15	57.74	58.57	33°33'28"	S-35-15-28-E
19	50.00	83.33	115.55	121.55	247°06'53"	S-71-31-15-W
20	100.00	30.15	57.74	58.57	33°33'28"	N-01-42-02-W
21	375.00	31.37	62.52	62.60	09°33'51"	N-13-41-50-W
22	110.00	123.31	164.17	185.32	96°31'42"	N-39-20-56-E
23	325.00	70.33	137.48	138.52	24°25'16"	S-80-10-35-E
24	25.00	13.58	23.87	24.88	57°01'34"	N-83-31-15-E
25	105.00	19.36	38.08	38.59	65°38'46"	N-73-49-56-E
26	105.00	78.82	126.07	135.22	73°47'12"	S-67-12-10-E
27	25.00	16.67	27.74	29.40	67°22'48"	S-63-59-58-E
28	25.00	27.96	37.28	42.07	96°24'24"	S-34-06-26-W
29	105.00	69.23	115.59	122.41	66°47'42"	S-19-18-04-W
30	25.00	17.03	28.15	29.90	68°32'10"	S-18-25-50-W
31	125.00	56.37	102.77	105.91	48°32'52"	S-40-06-41-E
32	50.00	30.11	51.58	54.20	62°06'18"	N-73-49-56-E
33	105.00	10.05	20.00	20.03	10°55'48"	S-58-27-52-E
34	25.00	10.16	18.82	19.30	44°13'39"	S-37-57-05-E
35	175.00	42.41	82.44	83.22	27°14'52"	S-29-27-41-E
36	1200.00	20.37	40.74	40.74	01°56'43"	S-32-56-07-W
37	25.00	23.71	34.40	37.94	86°57'30"	S-75-26-30-W
38	2040.00	6.36	12.72	12.72	00°21'28"	N-61-15-28-W
39	25.00	15.13	27.10	28.85	65°38'46"	N-49-29-14-E
40	55.00	55.00	77.78	86.39	90°00'01"	S-59-05-46-E
41	55.00	55.00	77.78	86.39	90°00'01"	S-30-54-13-W
42	55.00	55.00	77.78	86.39	90°00'00"	N-59-05-46-W
43	55.00	55.00	77.78	86.39	90°00'00"	N-30-54-14-E
44	150.00	67.65	123.33	127.10	48°32'52"	N-40-06-41-W
45	80.00	80.00	113.14	125.66	90°00'00"	N-59-05-46-W
46	80.00	80.00	113.14	125.66	90°00'00"	N-30-54-14-E
47	80.00	80.00	113.14	125.66	90°00'00"	S-59-05-46-E
48	80.00	80.00	113.14	125.66	90°00'00"	S-30-54-13-W
49	350.00	29.28	58.36	58.42	09°33'51"	N-13-41-50-W
50	85.00	95.28	126.86	143.20	96°31'42"	N-39-20-56-E
51	300.00	81.58	157.44	155.30	30°25'27"	S-77-10-30-E

NAD83 GRID COORDINATES
X = 3,831,936.21
Y = 10,066,176.75

P.O.C. (NAD27)
X = 3,112,186.5720
Y = 873,655.6180

NAD83 GRID COORDINATES
X = 3,832,778.86
Y = 10,066,218.27

THE WOODLANDS LAND DEVELOPMENT COMPANY, L.P.
F.N. 9747722
M.C.R.P.R.

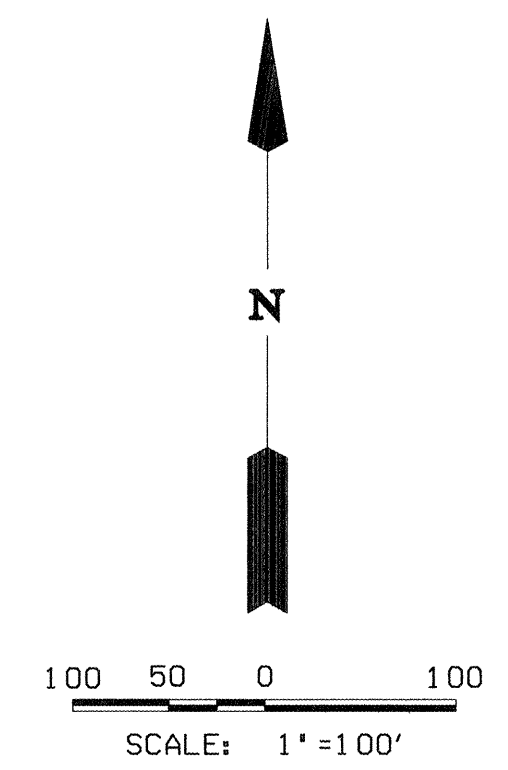

LINE	BEARING	DISTANCE
1	S-02-40-E	24.27
2	S-41-53-24-E	17.33
3	S-16-01-23-E	69.99
4	S-17-53-38-E	68.97
5	S-16-57-05-E	88.19
6	S-56-05-32-E	68.21
7	N-61-04-45-W	26.98
8	N-70-20-52-W	109.56
9	S-25-21-12-W	50.00
10	N-64-23-07-W	84.97
11	S-46-54-55-W	43.00
12	N-15-50-15-W	31.88
13	S-75-54-14-W	4.84
14	N-75-54-14-E	50.00
15	N-75-54-14-E	53.35
16	S-75-54-14-W	53.35
17	S-75-54-14-W	50.00
18	S-87-36-47-W	90.89
19	S-08-54-55-E	91.52
20	S-18-28-45-E	39.89
21	N-18-28-45-W	39.89
22	N-08-54-55-W	91.52
23	N-87-36-47-E	90.89
24	N-75-54-14-E	53.35
25	N-82-18-37-E	104.61
26	S-07-41-23-E	50.00
27	S-82-18-37-W	88.18
28	S-18-28-45-E	39.89
29	S-64-23-07-E	84.74
30	S-16-01-23-E	12.24
31	S-14-05-46-E	4.17
32	S-17-53-38-E	21.09
33	S-16-57-05-E	2.78
34	S-64-23-07-E	4.14
35	S-64-23-07-E	20.60
36	N-70-12-03-E	11.99
37	S-75-54-14-W	4.84
38	N-75-25-49-W	29.38
39	N-14-05-46-W	23.13
40	N-02-23-13-W	28.72
41	S-87-36-47-W	15.37
42	S-08-54-55-E	3.20
43	S-08-54-55-E	17.45
44	S-18-28-45-E	4.16
45	N-75-54-14-E	28.32
46	N-75-54-14-E	25.03
47	S-14-53-04-W	22.09
48	N-60-23-03-E	30.14
49	N-72-46-56-E	105.77
50	N-14-53-04-E	22.09
51	S-47-13-12-E	32.40
52	S-54-23-17-E	67.06
53	S-67-47-49-E	72.77
54	S-15-50-15-E	31.88
55	S-46-54-55-W	43.00
56	N-61-04-45-W	26.98
57	N-28-33-49-E	70.28
58	S-56-05-32-E	68.21
59	N-82-18-37-E	88.18
60	N-75-54-14-E	53.35
61	S-75-54-14-W	53.35
62	N-64-23-07-W	84.85
63	N-15-50-15-W	80.38
64	S-75-54-14-W	53.35
65	N-08-54-55-W	91.52
66	N-87-36-47-E	90.89

THE WOODLANDS LAND DEVELOPMENT COMPANY, L.P.
F.N. 9747722
M.C.R.P.R.

100 YEAR FLOOD PLAIN PER FEDERAL EMERGENCY MANAGEMENT AGENCY (FEMA) COMMUNITY PANEL NO. 48339C0540 F & NO. 48339C0537 G DATED: SEPTEMBER 22, 1999

GF-9 CONC. MON. WITH BRASS DISC ELEV. = 137.56

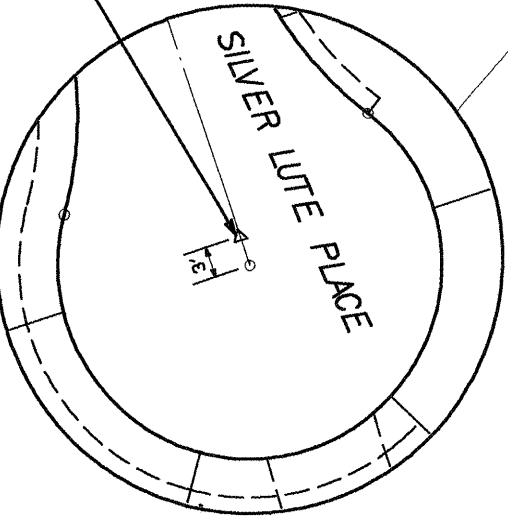

FLOWAGE EASEMENT
FILE NO. S. 2000-063946 & 2000-084700
M.C.R.P.R.

NAD83 GRID COORDINATES
X = 3,832,056.05
Y = 10,065,338.66

NAD83 GRID COORDINATES
X = 3,832,494.34
Y = 10,065,415.01

THE WOODLANDS GROGAN'S FOREST SEC. 8
THE WOODLANDS LAND DEVELOPMENT COMPANY, L.P.
F.N. 9747722
M.C.R.P.R.

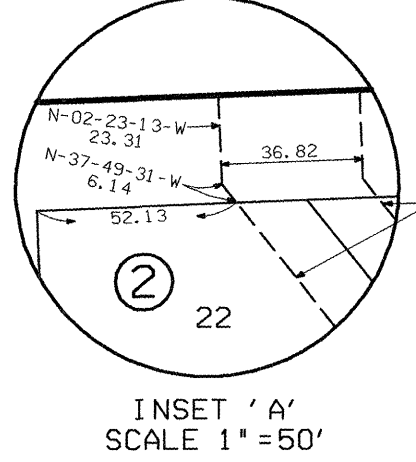

RESERVE	ACREAGE	SQ. FT.	TYPE
A	3.664	159,602	RESTRICTED TO OPEN SPACE
B	0.055	2,405	RESTRICTED TO OPEN SPACE
C	0.099	4,293	RESTRICTED TO OPEN SPACE
D	0.036	1,588	RESTRICTED TO OPEN SPACE
E	1.055	45,939	RESTRICTED TO OPEN SPACE
TOTAL	4.909	671,067	

- LEGEND**
- B.L. INDICATES BUILDING LINE
 - D.E. INDICATES DRAINAGE EASEMENT
 - STM.S.E. INDICATES STORM SEWER EASEMENT
 - S.S.E. INDICATES SANITARY SEWER EASEMENT
 - W.L.E. INDICATES WATER LINE EASEMENT
 - U.E. INDICATES UTILITY EASEMENT
 - M.C.M.R. INDICATES MONTGOMERY COUNTY MAP RECORDS
 - M.C.P.R. INDICATES MONTGOMERY COUNTY PLAT RECORDS
 - M.C.R.P.R. INDICATES MONTGOMERY COUNTY REAL PROPERTY RECORDS

OWNER: THE WOODLANDS LAND DEVELOPMENT COMPANY, L.P.
2201 TIMBERLOCH PLACE
THE WOODLANDS, TEXAS 77380

THE WOODLANDS GROGAN'S FOREST SECTION 9 SHEET 3 OF 3