

**THE WOODLANDS  
HARPER'S LANDING AT COLLEGE PARK, SECTION 5**

A SUBDIVISION OF  
**46.69 ACRES**

CONTAINING  
**2 BLOCKS - 183 LOTS  
& 3.44 AC. IN 3 RESERVES**

0.58 ACRES OUT OF THE THOMAS TOBY SURVEY, A-576,  
28.48 ACRES OUT OF THE JAMES McCAMBRIDGE SURVEY, A-390,  
and  
17.63 ACRES OUT OF THE RICHARD VINCE SURVEY, A-583  
MONTGOMERY COUNTY, TEXAS

**OWNER: THE WOODLANDS LAND  
DEVELOPMENT COMPANY, L.P.**  
2201 TIMBERLOCH PLACE - THE WOODLANDS, TEXAS 77380

**ENGINEER: PATE ENGINEERS, INC.**  
13405 N.W. FRWY., SUITE 300 - HOUSTON, TEXAS 77040  
AUGUST 1998    JOB No. 319-034-00

SHEET 1 OF 4

PATE ENGINEERS  
2211045001.PLAISECS.DWG, 12/15/09, 14:15:56, MACHN, (PS)

*File No. 2000-030667    Cab. N Sheet 103*

MONTGOMERY COUNTY, TEXAS  
COUNTY CLERK

STATE OF TEXAS  
COUNTY OF MONTGOMERY

THE WOODLANDS LAND DEVELOPMENT COMPANY, L.P., acting herein by and through The WOODLANDS OPERATING COMPANY, L.P. its authorized agent, acting herein by and through its President and Chief Executive Officer, Michael H. Richmond, owner (hereinafter referred to as "Owner") of the property subdivided in the above and foregoing map of THE WOODLANDS HARPER'S LANDING AT COLLEGE PARK, SECTION 5, do hereby make subdivision of said property for and on behalf of said THE WOODLANDS LAND DEVELOPMENT COMPANY, L.P., according to the lines, streets, lots, alleys, parks, building lines, and easements thereon shown and designate said subdivision as THE WOODLANDS HARPER'S LANDING AT COLLEGE PARK, SECTION 5 Located in the Thomas Toby Survey, Abstract 576, James McCambridge Survey, Abstract 390, and Richard Vince Survey, Abstract 583, in Montgomery County, Texas and on behalf of said THE WOODLANDS LAND DEVELOPMENT COMPANY, L.P.; and dedicate to public use, as such, the streets, alleys, parks and easements shown thereon forever; and do hereby waive any claims for damages occasioned by the establishing of grades as approved for the streets and alleys dedicated, or occasioned by the alteration of the surface of any portion of streets or alleys to conform to such grades; and do hereby bind myself, our successors and assigns to warrant and forever defend the title to the land so dedicated.

THIS is to certify that THE WOODLANDS LAND DEVELOPMENT COMPANY, L.P., acting herein by and through THE WOODLANDS OPERATING COMPANY, L.P. its authorized agent, acting herein by and through its President and Chief Executive Officer, Michael H. Richmond, Owner of the property subdivided in the above foregoing map of THE WOODLANDS HARPER'S LANDING AT COLLEGE PARK, SECTION 5, have complied or will comply with all regulations heretofore on file with the Montgomery County Engineer and adopted by the Commissioner's Court of Montgomery County, Texas.

FURTHER, Owner has dedicated and by these presents does dedicate to the use of the public for public utility purposes forever unobstructed aerial easements. The aerial easements shall extend horizontally an additional eleven feet, six inches (11'-6") for ten feet (10'-0") perimeter ground easements or five feet six inches (5'-6") for sixteen feet (16'-0") perimeter ground easements, from a plane sixteen feet (16'-0") above ground level upward, located adjacent to and adjoining said public utility easements that are designated with aerial easements (U.E. & A.E.) as indicated and depicted hereon, whereby the aerial easement totals twenty one feet, six inches (21'-6") in width.

FURTHER, Owner has dedicated and by these presents does dedicate to the use of the public for public utility purposes forever unobstructed aerial easements. The aerial easements shall extend horizontally an additional ten feet (10'-0") for ten feet (10'-0") back-to-back ground easements or seven feet (7'-0") for sixteen feet (16'-0") back-to-back ground easements, from a plane sixteen feet (16'-0") above ground level upward, located adjacent to both sides and adjoining said public utility easements that are designated with aerial easements (U.E. & A.E.) as indicated and depicted hereon, whereby the aerial easement totals thirty feet (30'-0") in width.

FURTHER, Owner does hereby dedicate forever to the public a strip, a minimum of land fifteen feet (15'-0") wide on each side of the centerline of any and all gullies, ravines, draws sloughs, or other natural drainage courses located in the said subdivision, as easements for drainage purposes, giving Montgomery County and/or any other public agency the right to enter upon said easements at any and all times for the purpose of constructing and/or maintaining drainage work and/or structures.

FURTHER, all of the property subdivided in the above and foregoing map shall be restricted in its use, which restrictions shall run with the title to the property, and shall be enforceable at the option of Montgomery County, by Montgomery County or any citizen thereof, by injunction as follows:

- 1) That drainage of septic tanks into any road, street, alley or other public ditches, either directly or indirectly, is strictly prohibited.
- 2) Drainage structures under private driveways shall have a net drainage opening area of sufficient size to permit the free flow of water without backwater, and shall be a minimum of one and three quarters (1-3/4) square feet (18" diameter pipe culvert).

FURTHER, Owner does hereby declare that all parcels of land designated as lots on this plat are originally intended for the construction of residential dwelling units thereon and shall be restricted for same under the terms and conditions of such restrictions filed separately, unless otherwise noted.

FURTHER, Owner does hereby certify that it is the owner of all property immediately adjacent to the boundaries of the above and foregoing plat of THE WOODLANDS HARPER'S LANDING AT COLLEGE PARK, SECTION 5 where building setback lines or public utility easements are to be established outside the boundaries of the above and foregoing plat and does hereby make and establish all building setback lines and dedicates to the use of the public forever all public utility easements shown in said adjacent acreage.

IN TESTIMONY WHEREOF, THE WOODLANDS OPERATING COMPANY, L.P., A TEXAS LIMITED PARTNERSHIP acting in its capacity as authorized agent of THE WOODLANDS LAND DEVELOPMENT COMPANY, L.P., A TEXAS LIMITED PARTNERSHIP, has caused these presents to be signed by Michael H. Richmond, its President and Chief Executive Officer, thereunto authorized, this the 17 day of November, 1999.

THE WOODLANDS LAND DEVELOPMENT COMPANY, L.P.,  
A Texas Limited Partnership

By: THE WOODLANDS OPERATING COMPANY, L.P.  
A Texas Limited Partnership  
Its Authorized Agent

By: Michael H. Richmond  
Name: Michael H. Richmond  
Title: President and Chief Executive Officer

STATE OF TEXAS  
COUNTY OF MONTGOMERY

BEFORE ME, the undersigned authority, on this day personally appeared Michael H. Richmond, President and Chief Executive Officer of THE WOODLANDS OPERATING COMPANY, L.P., a Texas Limited Partnership, Authorized Agent of THE WOODLANDS LAND DEVELOPMENT COMPANY, L.P., a Texas Limited Partnership, known to me to be the person whose name is subscribed to the foregoing instrument and acknowledged to me that he executed the same for the purposes and considerations therein expressed, and in the capacity therein and herein set out, and as an act and deed of said limited partnership.

GIVEN UNDER MY HAND AND SEAL OF OFFICE, this 17 day of Nov, 1999.

Delia Gonzales  
Notary Public in and for the State of Texas.

My Commission expires:

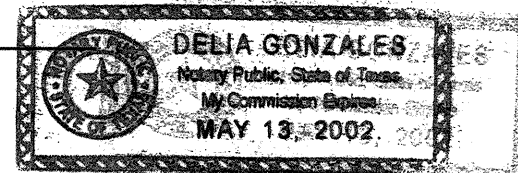

I, Mark J. Mooney, P.E., County Engineer of Montgomery County, Texas, do hereby certify that the plat of this subdivision complies with all of the existing rules and regulations of this office as adopted by the Montgomery County Commissioners' Court.

I further certify that the plat of this subdivision complies with requirements for internal subdivision drainage as adopted by the Commissioners' Court; however, no certification is hereby given as to the effect of drainage from this subdivision on the intercepting drainage artery or parent stream or on any other area of subdivision within the watershed.

Mark J. Mooney  
Mark J. Mooney, P.E.  
Montgomery County Engineer

I, John G. Davidson, am authorized under the laws of the State of Texas to practice the profession of surveying and hereby certify that the above subdivision is true and correct; was prepared from an actual survey of the property made under my supervision on the ground; that the elevation benchmark reflected on the face of the plat was established as required by regulation; that all corners and angle points of the boundaries of the original tract to be subdivided of reference have been marked with iron rods having a diameter of not less than five-eighths of an inch (5/8") and a length of not less than three feet (3'); and that the plat boundary corners have been tied to the nearest survey corner.

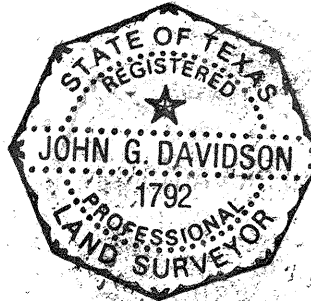

John G. Davidson  
John G. Davidson  
Registered Professional Land Surveyor  
Texas Registration No. 1792  
2271 Timberloch Place  
The Woodlands, Texas 77380

APPROVED by the Commissioners Court of Montgomery County, Texas, this 10 day of April, 2000.

Mike Meador  
Mike Meador  
Commissioner, Precinct 1

Malcolm Purvis  
Malcolm Purvis  
Commissioner, Precinct 2

Alan B. Sadler  
County Judge

Ed Chance  
Ed Chance  
Commissioner, Precinct 3

Ed Rinehart  
Ed Rinehart  
Commissioner, Precinct 4

I, Mark Turnbull, Clerk of the County Court of Montgomery County, do hereby certify that the within instrument with its certificate of authentication was filed for registration in my office on April 10, 2000, at 9:30 o'clock A.M., and duly recorded on April 13, 2000, at 12:39 o'clock P.M., in Cabinet N, Sheet 162-166, of record of Maps for said County.

WITNESS MY HAND AND SEAL OF OFFICE, at Conroe, Montgomery County, Texas, the day and date last above written.

Mark Turnbull  
Mark Turnbull, Clerk of the County Court  
Montgomery County, Texas.

By: Debra Matuszewski  
Deputy

FILED FOR RECORD

00 APR 13 PM 12:39

MARK TURNBULL, CO. CLERK

MONTGOMERY COUNTY, TEXAS

DEPUTY

OWNER: THE WOODLANDS LAND DEVELOPMENT COMPANY, L.P.  
2201 TIMBERLOCH PLACE  
THE WOODLANDS, TEXAS 77380

On the 3rd day of February, 2000, this plat was approved by the Planning and Zoning Commission of the City of Conroe, Texas. The approval will be automatically revoked if this plat is not filed in the Map Records of Montgomery County, Texas within one year of the date of approval.

WITNESS the official signatures of the Chairman and Secretary of the City Planning and Zoning Commission of the City of Conroe, Texas, this 9th day of February, 2000.

Chairman

Secretary

NOTES:

1. B.L. indicates a building line  
U.E. indicates a utility easement  
STM. SWR. ESM'T. indicates a storm sewer easement  
W.L.E. indicates a water line easement  
S.S.E. indicates a sanitary sewer easement  
VOL., PG. indicates Volume, Page  
M.C.M.R. indicates Montgomery County Map Records  
M.C.R.P.R. indicates Montgomery County Real Property Records  
M.C.O.P.R.R.P. indicates Montgomery County Official Public Records of Real Property  
Esm't. indicates Easement  
F.H.E. indicates a fire hydrant easement  
R.O.S.R. indicates a Restricted Open Space Reserve  
D.E. indicates a Drainage easement
2. One-foot reserve dedicated for buffer purposes to the public in fee as a buffer separation between the side or end of streets where such streets abut adjacent property, the condition of such dedication being that when the adjacent property is subdivided or re-subdivided in a recorded plat, the one-foot reserve shall thereupon become vested in the public for street right-of-way purposes and the fee title thereto shall revert to and revest in the dedicator, his heirs, assigns, or successors.
3. All non-perimeter easements on property lines are centered unless otherwise noted.
4. All bearings are based on the Texas State Plane Coordinate System, South Central Zone.
5. A 5-foot side lot building setback and 10-foot rear lot building setback is hereby established for all lots and buildable reserves included in the plat boundary, unless otherwise indicated.
6. All plat boundary corners are marked by set 5/8-inch iron rods.
7. Curves are tangent to adjoining lines, unless otherwise indicated by radial bearing call.
8. Concrete benchmark consists of a three-inch brass disk set in a concrete column six inches in diameter, three feet deep, and buried flush with the ground inside dedicated right-of-way but not within pavement.

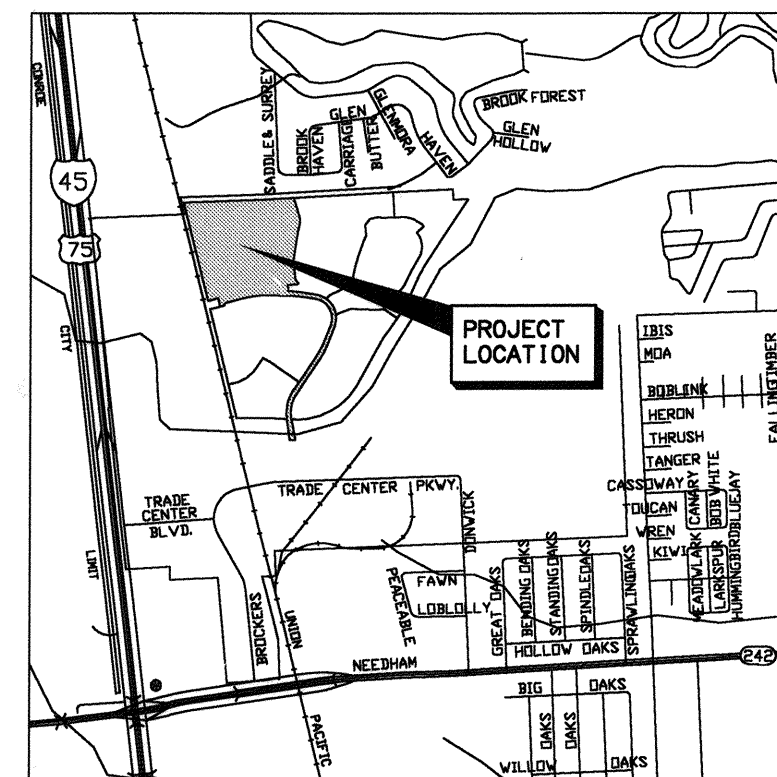

VICINITY MAP  
1" = 1/2 mile

THE WOODLANDS  
HARPER'S LANDING  
AT COLLEGE PARK  
SECTION 5  
SHEET 2 OF 4

File No. 2000-030667

Cab. N Sheet 184

ETHEL FULOCK  
MCNMR VOL. 865 PAGE 288

RIVER BROOK  
FOREST HILLS SECTION  
MCNMR VOL. 7 PAGE 437

N 86°51'38" E 630.26'

N 86°44'47" E 883.12'

Reserve 'B'  
118500 Sq. Ft.  
2.72 Ac.  
Restricted for  
Open Space

Reserve 'C'  
6700 Sq. Ft.  
0.15 Ac.  
Restricted for  
Drainage and  
Municipal Utility  
uses

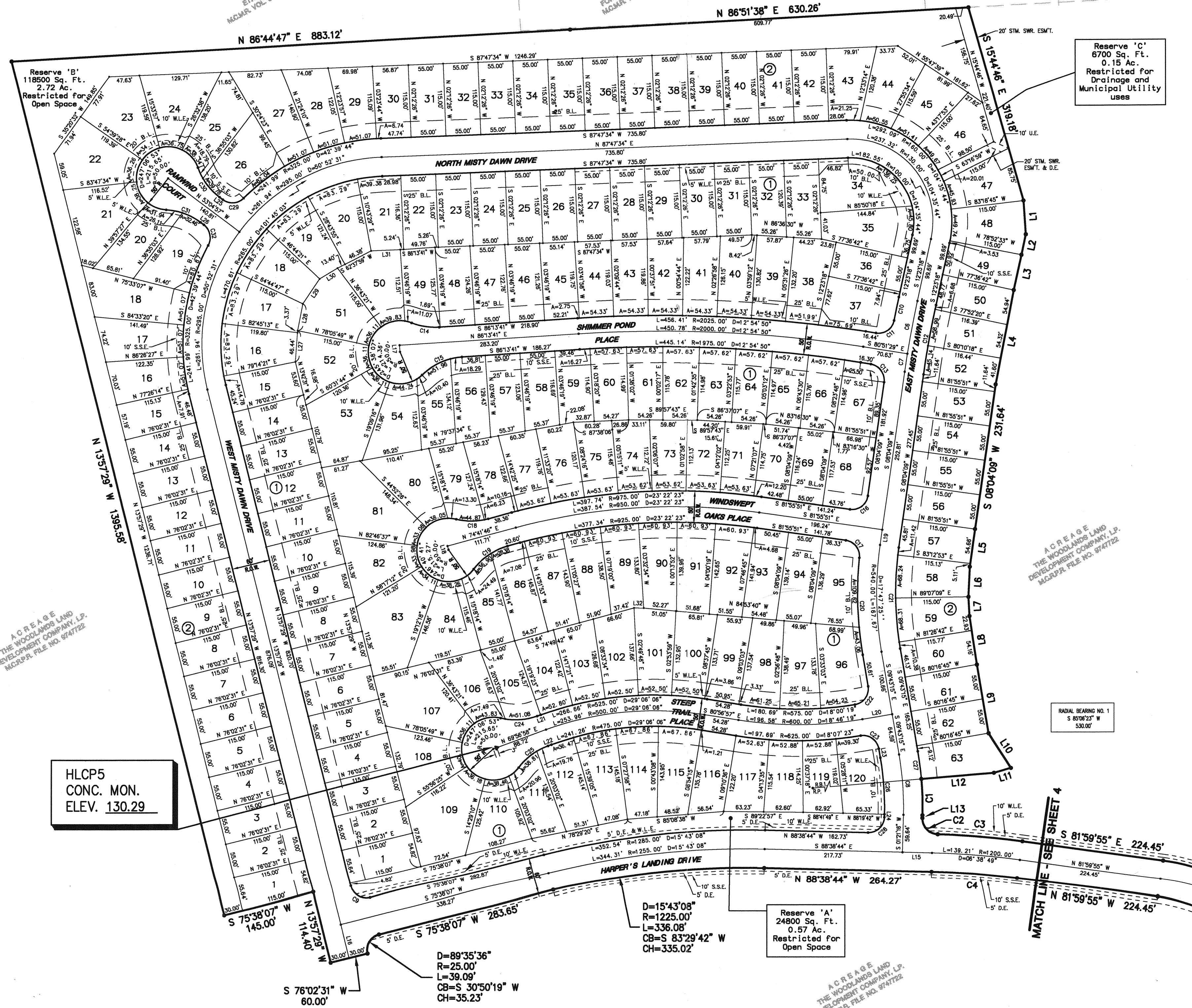

ACREAGE  
THE WOODLANDS LAND  
DEVELOPMENT COMPANY, L.P.  
MCNMR FILE NO. 874722

ACREAGE  
THE WOODLANDS LAND  
DEVELOPMENT COMPANY, L.P.  
MCNMR FILE NO. 874722

HLCPS  
CONC. MON.  
ELEV. 130.29

Reserve 'A'  
24800 Sq. Ft.  
0.57 Ac.  
Restricted for  
Open Space

D=89°35'36"  
R=25.00'  
L=39.09'  
CB=S 30°50'19" W  
CH=35.23'

D=15°43'08"  
R=1225.00'  
L=336.08'  
CB=S 83°29'42" W  
CH=335.02'

RADIAL BEARING NO. 1  
S 80°08'23" W  
530.00'

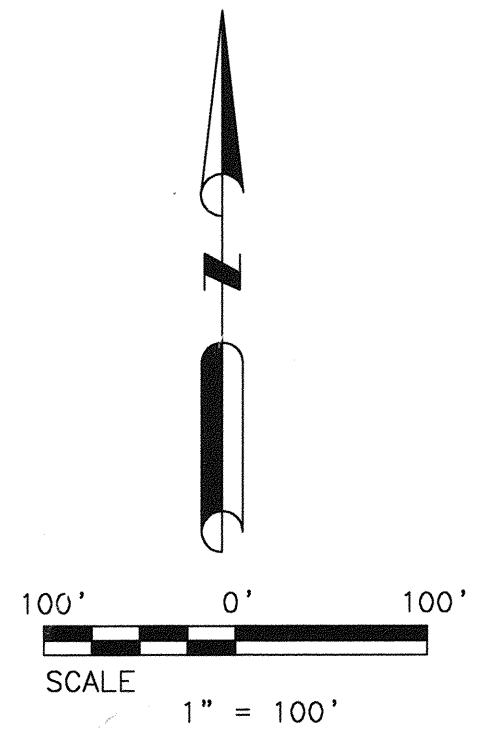

OWNER : THE WOODLANDS LAND DEVELOPMENT COMPANY, L.P.  
2201 TIMBERLOCH PLACE  
THE WOODLANDS, TEXAS 77380

THE WOODLANDS  
HARPER'S LANDING  
AT COLLEGE PARK  
SECTION 5  
SHEET 3 OF 4

File No. 2000-030667

Tab. N Sheet 105

DATE: 02/01/00 17:31:16 Mch-AN (PS)

ACREAGE  
THE WOODLANDS LAND  
DEVELOPMENT COMPANY, L.P.  
MCNMR FILE NO. 874722

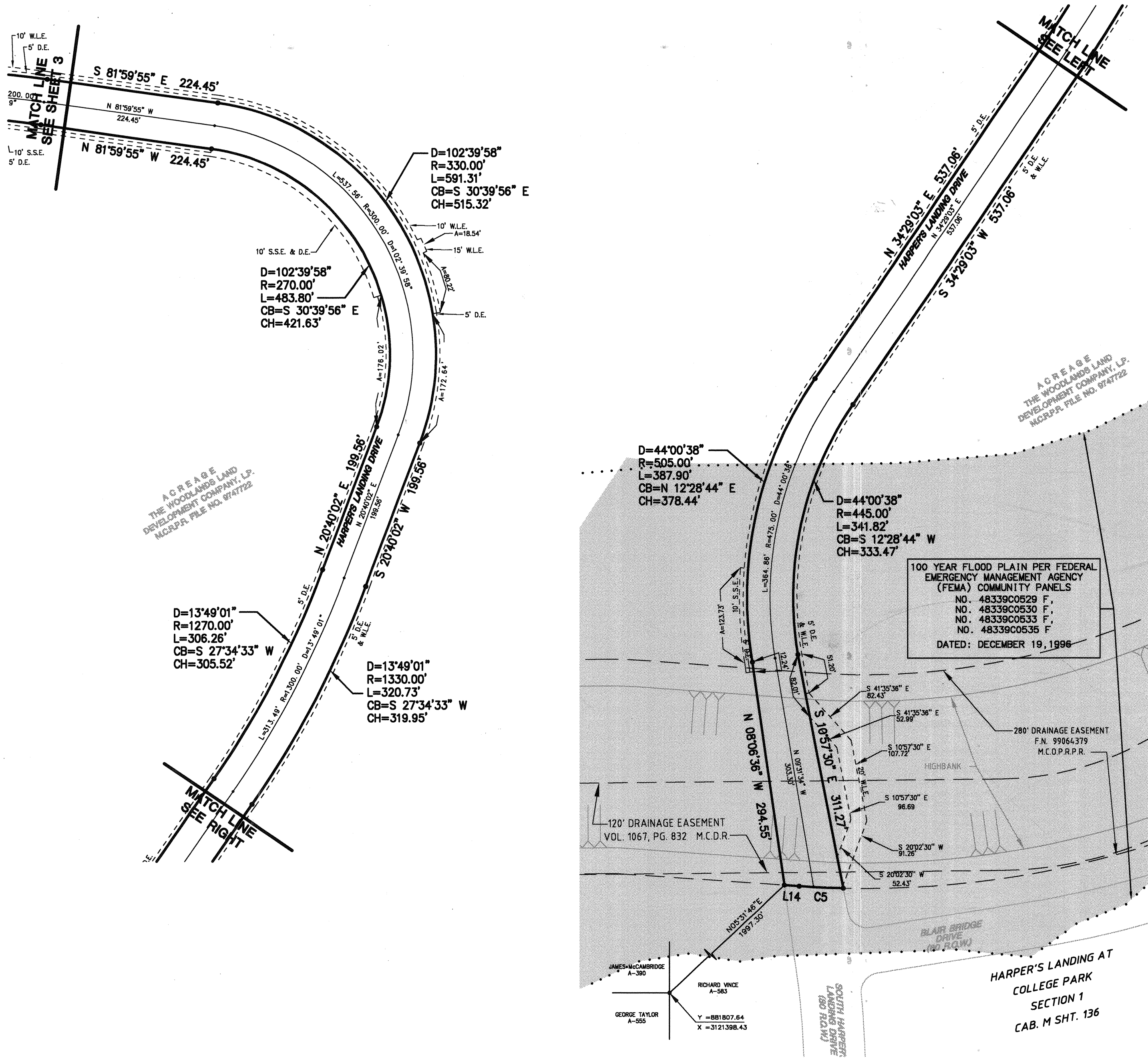

CURVE	DELTA ANGLE	RADIUS	ARC LENGTH	CHORD BEARING	CHORD LENGTH
C1	06°14'53"	530.00'	57.80'	S 01°46'10" E	57.77'
C2	89°36'51"	25.00'	39.10'	S 43°27'10" E	35.24'
C3	06°15'40"	1230.00'	134.41'	S 85°07'45" E	134.34'
C4	06°38'49"	1170.00'	135.73'	N 85°19'20" W	135.66'
C5	02°41'18"	1225.00'	57.48'	N 87°18'51" W	57.47'
C6	03°14'47"	1500.00'	84.99'	N 10°45'54" E	84.98'
C7	01°04'22"	1500.00'	28.08'	N 08°36'20" E	28.08'
C8	11°04'31"	500.00'	96.65'	S 04°11'00" E	96.50'
C9	90°24'24"	25.00'	39.45'	S 59°09'41" E	35.48'
C10	01°24'13"	1530.00'	37.48'	N 11°41'11" E	37.48'
C11	88°09'27"	25.00'	38.47'	N 55°03'48" E	34.78'
C12	04°19'08"	1470.00'	110.81'	N 10°13'43" E	110.78'
C13	88°55'38"	25.00'	38.80'	S 36°23'40" E	35.02'
C14	25°22'56"	100.00'	44.30'	S 81°04'51" E	43.94'
C15	40°15'11"	100.00'	70.25'	N 66°06'06" E	68.82'
C16	90°00'00"	25.00'	39.27'	N 53°04'09" E	35.36'
C17	87°33'27"	25.00'	38.20'	S 38°09'08" E	34.59'
C18	29°16'32"	100.00'	51.10'	N 89°20'03" E	50.54'
C19	37°24'08"	100.00'	65.28'	N 55°59'42" E	64.13'
C20	15°20'51"	570.00'	152.68'	S 02°02'50" E	152.23'
C21	17°47'25"	510.00'	158.35'	S 00°49'33" E	157.72'
C22	90°46'00"	25.00'	39.60'	N 35°39'45" E	35.59'
C23	89°21'05"	25.00'	38.99'	S 54°23'48" E	35.15'
C24	33°33'26"	100.00'	58.57'	N 86°43'41" E	57.74'
C25	33°33'26"	100.00'	58.57'	N 53°10'14" E	57.74'
C26	11°04'31"	470.00'	90.85'	S 04°11'00" E	90.71'
C27	04°49'39"	530.00'	44.65'	S 07°18'26" E	44.64'
C28	90°00'00"	25.00'	39.27'	N 46°21'16" E	35.36'
C29	81°47'13"	25.00'	35.69'	N 86°01'26" E	32.73'
C30	33°33'26"	100.00'	58.57'	S 36°18'14" E	57.74'
C31	33°33'26"	100.00'	58.57'	S 69°51'41" E	57.74'
C32	81°47'12"	25.00'	35.69'	S 12°11'21" E	32.73'

LINE	BEARING	DISTANCE
L1	S 03°50'03" E	53.19'
L2	S 12°04'58" W	32.74'
L3	S 12°19'15" W	56.99'
L4	S 10°55'36" W	150.87'
L5	S 07°49'58" W	59.77'
L6	S 02°34'55" W	47.71'
L7	S 03°03'14" E	29.95'
L8	S 08°49'06" E	77.09'
L9	S 09°43'15" E	110.00'
L10	S 32°38'24" E	65.40'
L11	S 73°46'17" W	27.93'
L12	S 85°06'23" W	115.00'
L13	S 01°21'16" W	4.67'
L14	N 85°58'12" W	19.43'
L15	N 88°38'44" W	46.55'
L16	N 13°57'29" W	54.61'
L17	S 03°46'19" E	10.52'
L18	S 15°18'14" E	5.84'
L19	S 08°04'09" W	24.64'
L20	N 80°16'45" E	47.64'
L21	N 69°56'58" E	5.81'
L22	N 69°56'58" E	5.81'
L23	S 09°43'15" E	14.64'
L24	S 01°21'16" W	4.64'
L25	N 53°04'57" W	6.48'
L26	S 53°04'57" E	6.48'
L27	S 04°06'07" W	49.81'
L28	S 10°52'53" W	43.09'
L29	S 34°15'26" W	46.95'
L30	N 58°47'43" E	33.00'
L31	N 87°36'09" E	45.96'
L32	S 89°15'11" E	15.15'

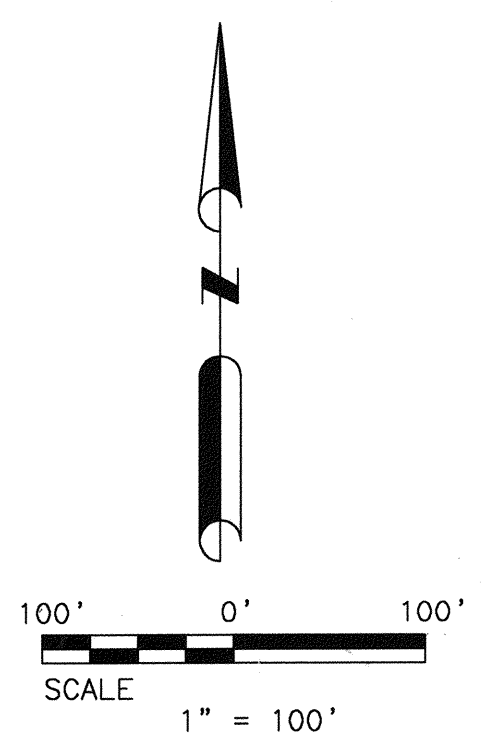

OWNER : THE WOODLANDS LAND DEVELOPMENT COMPANY, L.P.  
 2201 TIMBERLOCH PLACE  
 THE WOODLANDS, TEXAS 77380

THE WOODLANDS  
 HARPER'S LANDING  
 AT COLLEGE PARK  
 SECTION 5  
 SHEET 4 OF 4

PATE ENGINEERS  
 X:\131804500\PLAT\SEC5.DWG 02/01/00 17:31:45 Mch:CN (PS)

File No. 2000-030667

Cab. N Sheet 186